



# PROGRAMMING AND OPTIMIZATION FOR INTEL<sup>®</sup> ARCHITECTURE

The Hands-On Workshop (HOW) Series  
Session 3

*Colfax International* — [colfaxresearch.com](http://colfaxresearch.com)

September 2016

While best efforts have been used in preparing this training, Colfax International makes no representations or warranties of any kind and assumes no liabilities of any kind with respect to the accuracy or completeness of the contents and specifically disclaims any implied warranties of merchantability or fitness of use for a particular purpose. The publisher shall not be held liable or responsible to any person or entity with respect to any loss or incidental or consequential damages caused, or alleged to have been caused, directly or indirectly, by the information or programs contained herein. No warranty may be created or extended by sales representatives or written sales materials.

- ▶ HOW to Program Intel Architecture
  - 01. Parallelism, specialization, guided tour – Sep 26
  - 02. Programming Intel Xeon Phi (KNC, KNL) – Sep 27
- ▶ HOW to Express Parallelism
  - 03. Automatic vectorization – Sep 28
  - 04. Multi-threading with OpenMP – Sep 29
- ▶ HOW to Get Performance
  - 05. Comprehensive demo – Sep 30
  - 06. Scalar & vectorization tuning – Oct 3
  - 07. Multi-threading: common issues – Oct 4
  - 08. Multi-threading: memory aspect – Oct 5
  - 09. Memory traffic – Oct 6
- ▶ HOW to Scale
  - 10. Distributed Computing: MPI – Oct 7

September 2016						
S	M	T	W	H	F	S
				1	2	3
4	5	6	7	8	9	10
11	12	13	14	15	16	17
18	19	20	21	22	23	24
25	26	27	28	29	30	

October 2016						
S	M	T	W	H	F	S
						1
2	3	4	5	6	7	8
9	10	11	12	13	14	15
16	17	18	19	20	21	22
23	24	25	26	27	28	29
30	31					

■ — Webinar+remote access

Course page: [colfaxresearch.com/how-16-09](http://colfaxresearch.com/how-16-09)

- ▶ Slides (including this one), code downloads
- ▶ Video of recorded sessions
- ▶ Chat (during webinars or offline)



Additional resources:

- ▶ More workshops like this one: [colfaxresearch.com/training](http://colfaxresearch.com/training)
- ▶ Video courses: [colfaxresearch.com/video-courses](http://colfaxresearch.com/video-courses)

# GET YOUR QUESTIONS ANSWERED

## Chat (current):

[colfaxresearch.com/how-16-09](http://colfaxresearch.com/how-16-09)



## Forums (technical):

[colfaxresearch.com/discussion](http://colfaxresearch.com/discussion)

### COLFAX RESEARCH

CONTRIBUTING TO INNOVATIONS IN COMPUTING

[Log In/Register](#)

[/](#) [READ](#) [WATCH](#) [LEARN](#) [FORUMS](#) [CONNECT](#) [JOIN](#)

#### Join the Conversation

Welcome to Colfax Research forums, an online community for you to engage with HPC experts, software architects, developers, computational researchers, scientists, students and more—so you can acquire new knowledge, share ideas, and build new relationships.

Tap our experts and your peers to help meet the challenge of optimizing applications on modern hardware. This is the place to browse or post questions (and get answers) related to computational science, parallel programming and code modernization on Intel® Architecture.

Welcome aboard. Post questions today!

## Email (organizational):

[training@colfax-intl.com](mailto:training@colfax-intl.com)

# HANDS-ON EXERCISES AND REMOTE ACCESS

- ▶ 96 people receive a remote access token
- ▶ Virtualized Intel Xeon CPU, real Intel Xeon Phi coprocessor (1st gen, KNC), SW tools
- ▶ Can access the system the entire 2 weeks of the workshop

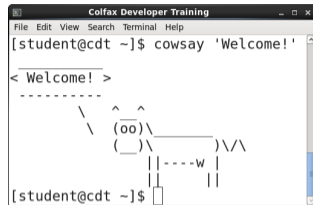

```
Colfax Developer Training
File Edit View Search Terminal Help
[student@cdt ~]$ cowsay 'Welcome!'
< Welcome! >
-----
      \   ^__^
         (oo)\_______
            (__)\       )\/\
                ||----w |
                ||     ||

[student@cdt ~]$
```

- ▶ Not among the 96? Stay tuned: follow along with instructor, use own system, or wait for a seat
- ▶ Use it or lose it: if you do not log in for a while, remote access token goes to next student on the list



## **§2. EXPRESSING DATA PARALLELISM**



# **VECTOR INSTRUCTIONS IN INTEL ARCHITECTURE**

## Intel Xeon Processor



Current: Broadwell  
Upcoming: Skylake

Multi-Core Architecture

## Intel Xeon Phi Coprocessor, 1st generation

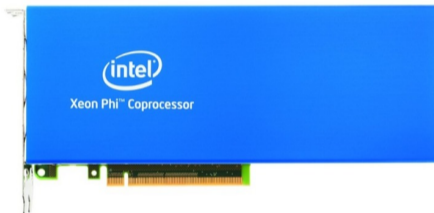

Knights Corner (KNC)

## Intel Xeon Phi Processor, 2nd generation\*



\* socket and coprocessor versions

Knights Landing (KNL)

Intel Many Integrated Core (MIC) Architecture

# KNL CORES

- ▶ Even more power in vector units
- ▶ Binary compatible with Xeon, but in legacy mode

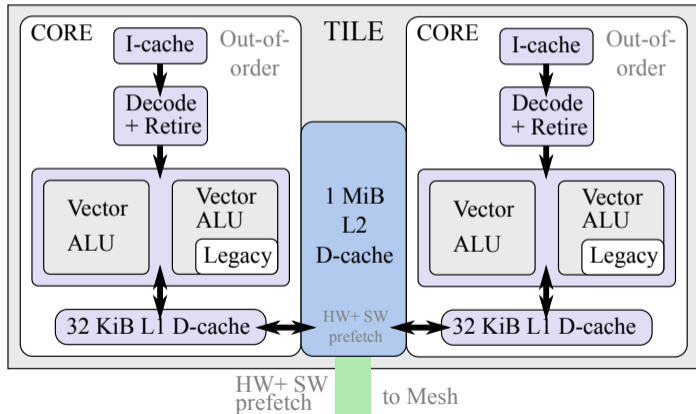
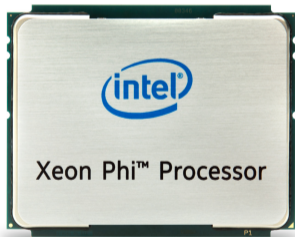

# SHORT VECTOR SUPPORT

Vector instructions – one of the implementations of SIMD (Single Instruction Multiple Data) parallelism.

Scalar Instructions

$$\begin{array}{r} 4 + 1 = 5 \\ 0 + 3 = 3 \\ -2 + 8 = 6 \\ 9 + -7 = 2 \end{array}$$

Vector Instructions

$$\begin{array}{r} 4 \\ 0 \\ -2 \\ 9 \end{array} + \begin{array}{r} 1 \\ 3 \\ 8 \\ -7 \end{array} = \begin{array}{r} 5 \\ 3 \\ 6 \\ 2 \end{array}$$

Vector Length

# INSTRUCTION SETS IN INTEL ARCHITECTURE

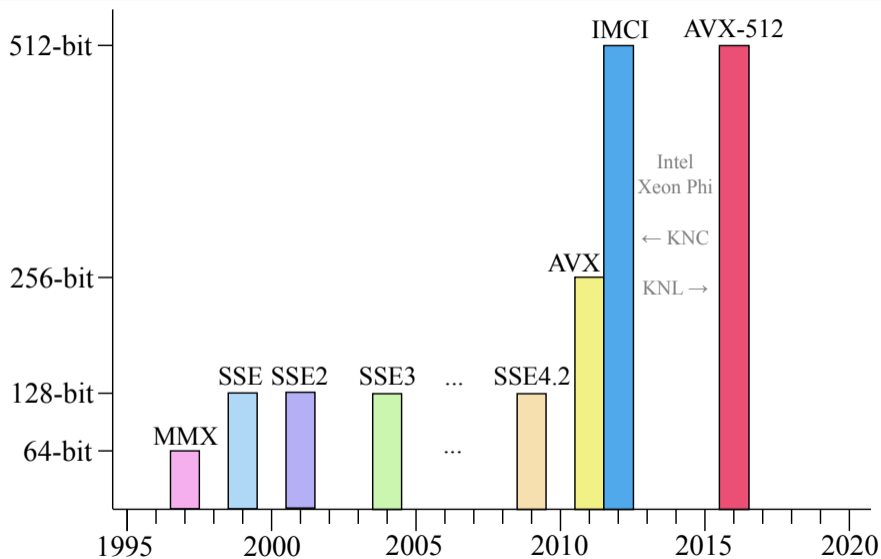

<https://software.intel.com/sites/landingpage/IntrinsicsGuide>

The Intel Intrinsics Guide is an interactive reference tool for Intel intrinsic instructions, which are C style functions that provide access to many Intel instructions - including Intel® SSE, AVX, AVX-512, and more - without the need to write assembly code.

MMX  
 SSE  
 SSE2  
 SSE3  
 SSSE3  
 SSE4.1  
 SSE4.2  
 AVX  
 AVX2  
 FMA  
 AVX-512  
 KNC  
 SVML  
 Other

Application-Targeted  
 Arithmetic  
 Bit Manipulation  
 Cast  
 Compare  
 Convert  
 Cryptography  
 Elementary Math  
 Functions  
 General Support

```

__m128i_mm_add_epi16 (__m128i a, __m128i b)           paddw
__m128i_mm_add_epi32 (__m128i a, __m128i b)         paddq
__m128i_mm_add_epi64 (__m128i a, __m128i b)         paddq
__m128i_mm_add_epi8 (__m128i a, __m128i b)          paddb
__m128d_mm_add_pd (__m128d a, __m128d b)            addpd
    
```

**Synopsis**

```

__m128d_mm_add_pd (__m128d a, __m128d b)
#include "emmintrin.h"
Instruction: addpd xmm, xmm
CPUID Flags: SSE2
    
```

**Description**

Add packed double-precision (64-bit) floating-point elements in a and b, and store the results in dst.

**Operation**

```

FOR j := 0 to 1
  i := j*64
  dst[i+63:i] := a[i+63:i] + b[i+63:i]
ENDFOR
    
```

**Performance**

Architecture	Latency	Throughput
Haswell	3	0.8
Ivy Bridge	3	1

# DETECTING AVAILABLE INSTRUCTIONS

In the OS:

```
[student@cdt ~]% cat /proc/cpuinfo
...
fpu_exception   : yes
cpuid level     : 11
wp              : yes
flags           : fpu vme de pse tsc msr pae mce
cx8 apic mtrr pge mca cmov pat pse36 clflush mmx
fxsr sse sse2 ss ht syscall nx lm constant_tsc
unfair_spinlock pni ssse3 cx16 sse4_1 sse4_2
x2apic popcnt aes hypervisor lahf_lm fsgsbase
bogomips       : 5985.17
clflush size   : 64
cache_alignment: 64
address sizes  : 46 bits physical, 48 bits virtual
...
```

In code (see also):

```
1 // Intel compiler
2 // preprocessor macros:
3
4 #ifdef __SSE__
5 // ...SSE code path
6 #endif
7
8 #ifdef __SSE4_2__
9 // ...SSE code path
10 #endif
11
12 #ifdef __AVX__
13 // ...AVX code path
14 #endif
```



## **EXPLICIT VECTORIZATION, INTRINSICS**

# WORKFLOW OF VECTOR COMPUTATION

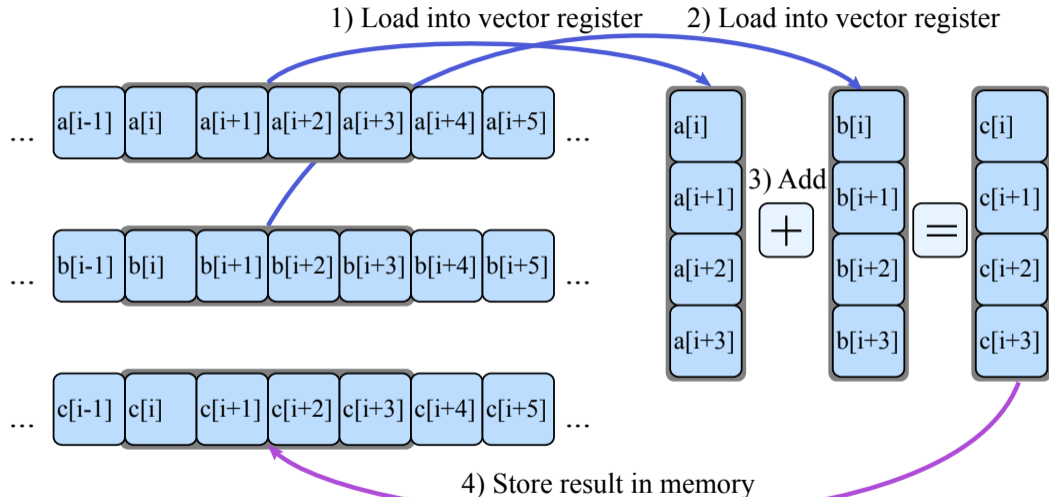

# EXAMPLE: NUMERICAL INTEGRATION

$$I(a, b) = \int_a^b \frac{1}{\sqrt{x}} dx$$

Rectangle method:

$$\Delta x = \frac{b-a}{n},$$

$$x_i = (i+1)\Delta x,$$

$$I(a, b) = \sum_{i=0}^{n-1} \frac{1}{\sqrt{x_i}} \Delta x + O(\Delta x).$$

```

1 float Integrate(const float a,
2                 const float b,
3                 const int N) {
4     const float dx = (b-a)/float(n);
5     float S = 0.0f;
6     for (int i = 0; i < n; i++) {
7         const float xi = dx*float(i+1);
8         S += 1.0f/sqrtf(xi) * dx;
9     }
10    return S;
11 }

```

# IMPLEMENTATION WITH SSE4.2

```

1 float Integrate(const float a,
2                 const float b, const int n) {
3     __m128 dx = _mm_set1_ps((b - a)/float(n));
4     __m128 S  = _mm_set1_ps(0.0f);
5     for (int i = 0; i < n; i += 4) {
6         __m128i ip1 =
7             _mm_set_epi32(i+4, i+3, i+2, i+1);
8         __m128 ip1f = _mm_cvtepi32_ps(ip1);
9         __m128 xi = _mm_mul_ps(dx, ip1f);
10        __m128 fi = _mm_rsqrt_ps(xi);
11        __m128 dS = _mm_mul_ps(fi, dx);
12        S = _mm_add_ps(S, dS);
13    }
14    ConverterType c;
15    c.v = S;
16    return c.f[0] + c.f[1] + c.f[2] + c.f[3];
17 }

```

That is fine, *but...*

- ▶ Assuming  $n$  is a multiple of 4
- ▶ Only for SSE4.2 (circa 2011)
- ▶ No memory access. If we had some, peeling may be needed



# **AUTOMATIC VECTORIZATION OF LOOPS**

# AUTOMATIC VECTORIZATION OF LOOPS

```

1 #include <stdio>
2
3 int main(){
4     const int n=8;
5     int i;
6     int A[n] __attribute__((aligned(64)));
7     int B[n] __attribute__((aligned(64)));
8
9     // Initialization
10    for (i=0; i<n; i++)
11        A[i]=B[i]=i;
12
13    // This loop will be auto-vectorized
14    for (i=0; i<n; i++)
15        A[i]+=B[i];
16
17    // Output
18    for (i=0; i<n; i++)
19        printf("%2d %2d %2d\n", i, A[i], B[i]);
20 }

```

```

vega@lyra% icpc autovec.cc -qopt-report
vega@lyra% cat autovec.optrpt
...
LOOP BEGIN at autovec.cc(14,3)
remark #15399: vectorization support:
unroll factor set to 2 [autovec.cc(14,3)]
remark #15300: LOOP WAS VECTORIZED
[autovec.cc(14,3)]
LOOP END
...
vega@lyra% ./a.out
0 0 0
1 2 1
2 4 2
3 6 3
4 8 4
5 10 5
6 12 6
7 14 7

```

# LIMITATIONS ON AUTOMATIC VECTORIZATION

- ▶ Number of iterations must be known before start of loop
- ▶ Only innermost loops (possible to override)
- ▶ No vector dependence allowed
- ▶ Functions called from vector loops must be SIMD-enabled

## VECTORIZE MORE LOOPS: `#pragma simd`

Statement `#pragma simd` is used to “enforce vectorization of loops”, which includes:

- ▶ Loops with SIMD-enabled functions (see below)
- ▶ Second innermost loops
- ▶ Failed vectorization due to compiler decision
- ▶ Loops where guidance is required (vector length, reduction, etc.)

See compiler reference on `#pragma simd` for more information.

## EXAMPLE FOR #pragma simd

```
1  const int N=128;
2  const int T=4;
3  float A[N*N], B[N*N], C[T*T];
4
5  for (int jj = 0; jj < N; jj+=T) // Tile in j
6      for (int ii = 0; ii < N; ii+=T) // and tile in i
7          // Using pragma simd to vectorize outer loop:
8          #pragma simd
9          for (int k = 0; k < N; ++k) // long loop, vectorize it
10             for (int i = 0; i < T; i++) { // Loop between ii and ii+T
11                 // Instead of a loop between jj and jj+T, unrolling that loop:
12                 C[0*T + i] += A[(jj+0)*N + k]*B[(ii+i)*N + k];
13                 C[1*T + i] += A[(jj+1)*N + k]*B[(ii+i)*N + k];
14                 C[2*T + i] += A[(jj+2)*N + k]*B[(ii+i)*N + k];
15                 C[3*T + i] += A[(jj+3)*N + k]*B[(ii+i)*N + k];
16             }
```

# AUTO-VECTORIZED LOOPS MAY BE COMPLEX (EXAMPLE 1)

```
1  for (int i = ii; i < ii + tileSize; i++) { // Target for auto-vectorization
2
3  // Newton's law of universal gravity
4  const float dx = particle.x[j] - particle.x[i]; // x[j] is a const
5  const float dy = particle.y[j] - particle.y[i]; // x[i] makes SIMD vector
6  const float dz = particle.z[j] - particle.z[i];
7  const float rr = 1.0f/sqrtf(dx*dx + dy*dy + dz*dz + softening);
8  const float drPowerN32 = rr*rr*rr;
9
10 // Calculate the net force
11 Fx[i-ii] += dx * drPowerN32;
12 Fy[i-ii] += dy * drPowerN32;
13 Fz[i-ii] += dz * drPowerN32;
14 }
```

See also [this presentation](#)

# AUTO-VECTORIZED LOOPS MAY BE COMPLEX (EXAMPLE 2)

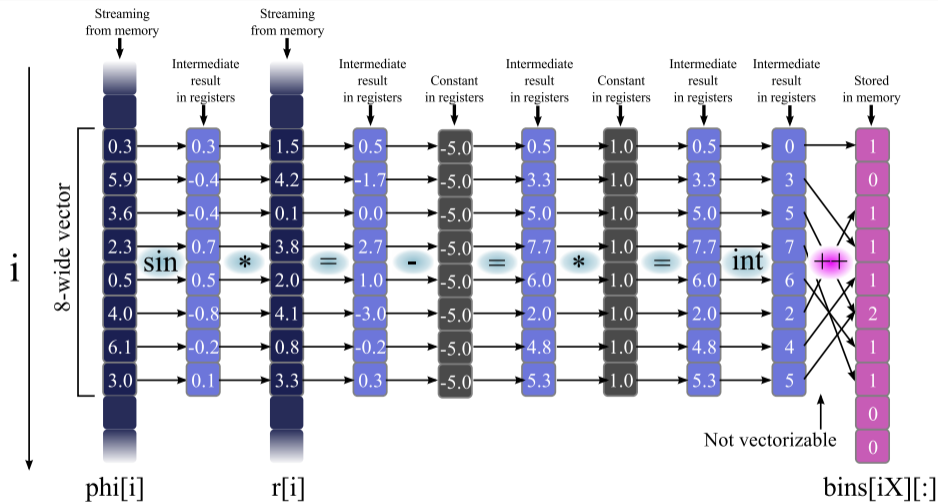

See [this paper](#) for more details

# ARRAY NOTATION

# EXTENSIONS FOR ARRAY NOTATION

Array notation is a method for specifying

- ▶ slices of arrays (begin, length)

```
1 A[0:16] += B[32:16]; // B[32]...B[47] added to A[0]...A[15]
```

- ▶ a stride (begin, length, stride)

```
1 A[0:16:2] += B[32:16:4]; // B[32],B[36]...B[92] added A[0],A[2]...A[30]
```

- ▶ Multi-dimensional arrays

```
1 A[:, :] += B[:, :]; // Add B to A; arrays are of the same shape
```

Better than strided loops (e.g., [this paper](#)).

# EXPRESSIONS WITH ARRAY NOTATION MAY BE COMPLEX

Example from <http://xeonphi.com/papers/efft>

```

1 evenrek[:] = evens[kk :kTILE:2];
2 evenimk[:] = evens[kk+1:kTILE:2];
3 oddrek [:] = odds [kk :kTILE:2];
4 oddimk [:] = odds [kk+1:kTILE:2];
5
6 evens[kk :kTILE:2] = evenrek[:] + coslist[:] * oddrek[:] - sinlist[:] * oddimk[:];
7 evens[kk+1:kTILE:2] = evenimk[:] + sinlist[:] * oddrek[:] + coslist[:] * oddimk[:];
8
9 oddmirrek[:] = odds[size-kk :kTILE:-2];
10 oddmirimk[:] = odds[size-kk+1:kTILE:-2];
11
12 odds[size-kk :kTILE:-2] =
13     evenrek[:] - coslist[:] * oddrek[:] + sinlist[:] * oddimk[:];
14 odds[size-kk+1:kTILE:-2] =
15     -evenimk[:] + sinlist[:] * oddrek[:] + coslist[:] * oddimk[:];
16 // ...

```



## **SIMD-ENABLED FUNCTIONS**

# SIMD-ENABLED FUNCTIONS

(formerly “elemental functions”)

What if the implementation of a function is in a separate source code file (e.g., a library function)?

```
1 float my_simple_add(float x1, float x2){  
2     return x1 + x2;  
3 }
```

```
1 // ...in a separate source file:  
2 for (int i = 0; i < N, ++i) {  
3     output[i] = my_simple_add(inputa[i], inputb[i]);  
4 }
```

Compiler will refuse to automatically vectorize this loop.

# SIMD-ENABLED FUNCTIONS MAY BE COMPLEX

Example from <http://xeonphi.com/papers/simd-lib>

```

1  __attribute__((vector)) float MyErfElemental(const float inx){
2      // Computes analytic approximation of the error function
3      const float x = fabsf(inx); // Take absolute value (in each vector lane)
4      const float p = 0.3275911f; // Constant parameter across vector lanes
5      const float t = 1.0f/(1.0f+p*x); // Expression in each vector lanes
6      const float l2e = 1.442695040f; // log2f(expf(1.0f))
7      const float e = exp2f(-x*x*l2e); // Transcendental in each vector lane
8      float res = -1.453152027f + 1.061405429f*t; // Computing a polynomial
9      res = 1.421413741f + t*res; // in each vector lane
10     res = -0.284496736f + t*res;
11     res = 0.254829592f + t*res;
12     res *= e;
13     res = 1.0f - t*res; // Analytic approximation in each vector lane
14     return copysignf(res, inx); // Copy sign in each vector lane
15 }

```



## HELPING THE COMPILER

## TARGETING A SPECIFIC INSTRUCTION SET

`-x [code]` instructs the compiler to target specific processor features, including instruction sets and optimizations.

code	Target architecture
MIC-AVX512	Intel Xeon Phi processors (KNL)
CORE-AVX512	Fugure Intel Xeon processors
CORE-AVX2	Intel Xeon processor E3 v3 family
CORE-AVX-I	Intel Xeon processor E3 v2, E5 v2 and E7 v2 family
AVX	Intel Xeon processor E3 and E5 family
SSE4.2	Intel Xeon processor 55XX, 56XX, 75XX and E7 family
host	architecture on which the code is compiled

# ASSUMED VECTOR DEPENDENCE

- ▶ True vector dependence makes vectorization impossible:

```

1 float *a, *b;
2 for (int i = 1; i < n; i++)
3     a[i] += b[i]*a[i-1]; // dependence on the previous element
  
```

- ▶ *Assumed vector dependence*: when compiler cannot determine whether vector dependence exists, auto-vectorization fails:

```

1 void mycopy(int n,
2             float* a, float* b) {
3     for (int i = 0; i < n; i++)
4         a[i] = b[i];
5 }
  
```

```

vega@lyra% icpc -c vdep.cc -qopt-report \
> -qopt-report-phase:vec
vega@lyra% cat vdep.optrpt
...
remark #15304: loop was not
vectorized: non-vectorizable loop
instance from multiversioning
...
  
```

# IGNORING ASSUMED VECTOR DEPENDENCE

## To ignore assumed vector dependence

```
#pragma ivdep
```

```
1 void mycopy(int n,  
2           float* a, float* b) {  
3     #pragma ivdep  
4     for (int i = 0; i < n; i++)  
5         a[i] = b[i];  
6 }
```

```
vega@lyra% icpc -c vdep.cc -qopt-report \  
> -qopt-report-phase:vec  
vega@lyra% cat vdep.optrpt  
...  
LOOP BEGIN at vdep.cc(4,1)  
<Multiversed v2>  
remark #15300: LOOP WAS VECTORIZED  
LOOP END
```

# MULTIVERSIONING

```
user@host% icpc -c code.cc -qopt-report -qopt-report-phase:vec
user@host% cat code.optrpt
...
LOOP BEGIN at code.cc(4,1)
<Multiversiomed v1>
    remark #25228: LOOP WAS VECTORIZED
LOOP END
...
LOOP BEGIN at code.cc(4,1)
<Multiversiomed v2>
    remark #15304: loop was not vectorized: non-vectorizable loop instance ....
LOOP END
```

Aliasing (true vector dependence) checked at *runtime* to choose the implementation.

# POINTER DISAMBIGUATION TO PREVENT MULTIVERSIONING

Prevent multiversioning by using `#pragma ivdep`

```
1 #pragma ivdep
2   for (int i = 0; i < n; i++)
3     // ...
```

```
user@host% icpc -c code.cc -qopt-report -qopt-report-phase:vec
user@host% cat vdep.optrpt
...
LOOP BEGIN at code.cc(4,1)
  remark #25228: LOOP WAS VECTORIZED
LOOP END
...
```

When keyword `restrict` is used instead, may not disambiguate different offsets of same pointer (e.g, `A[i*n+j] += A[b*n+j]`).

# VECTORIZATION PRAGMAS, KEYWORDS AND COMPILER ARGUMENTS

- ▷ `#pragma simd`
- ▷ `#pragma vector always`
- ▷ `#pragma vector aligned | unaligned`
- ▷ `__assume_aligned` keyword
- ▷ `#pragma vector nontemporal | temporal`
- ▷ `#pragma novector`
- ▷ `#pragma ivdep`
- ▷ `restrict` qualifier and `-restrict` command-line argument
- ▷ `#pragma loop count`
- ▷ `-qopt-report -qopt-report-phase:vec`
- ▷ `-O[n]`
- ▷ `-x[code]`



**LOOP WAS VECTORIZED, WHAT NOW?**

## LOOP WAS VECTORIZED, NOW WHAT?

1. Ensure unit stride access
2. Align data
3. Pad multi-dimensional containers
4. Eliminate peel loops
5. Eliminate multiversioning
6. **Optimize data re-use in caches**

### Good to Know

Vector FLOPs are cheap compared to memory access.

If your data is served by RAM and not caches, it does not matter if you have vectorization: you will be bottlenecked by memory access.

## REVIEW AND WHAT'S NEXT

Discussed today:

- ▶ Vectorization – support for data parallelism in each core
- ▶ Automatic vectorization enabled at default optimization level
- ▶ Loops, SIMD-enabled functions, array notation
- ▶ Argument `-qopt-report` produces a report on vectorization success

Later in the course – tuning automatic vectorization:

- ▶ alignment
- ▶ unit-stride data structures
- ▶ vectorization pattern regularization
- ▶ programming techniques for exposing automatic vectorization
- ▶ compiler hints.

# WHAT'S NEXT

Next session: expressing thread parallelism with OpenMP.

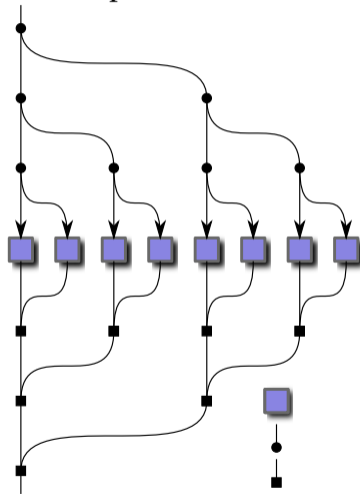
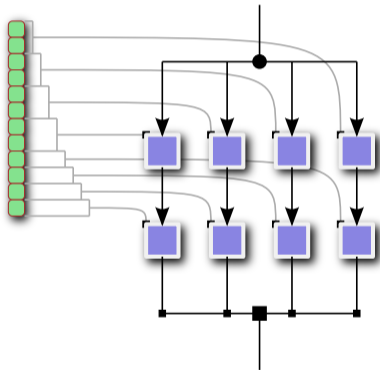



**LEARN MORE**

# HOW SERIES: KNIGHTS LANDING

HOW SERIES "KNIGHTS LANDING":

PROGRAMMING AND OPTIMIZATION FOR  
INTEL XEON PHI X200 FAMILY

Free 2-hour video course



[colfaxresearch.com/how-knl/](http://colfaxresearch.com/how-knl/)

ISBN: 978-0-9885234-0-1 (508 pages, Electronic or Print)

Parallel Programming  
and Optimization with  
Intel® Xeon Phi™  
Coproprocessors

Handbook on the Development and  
Optimization of Parallel Applications  
for Intel® Xeon® Processors  
and Intel® Xeon Phi™ Coprocessors

© Colfax International, 2015

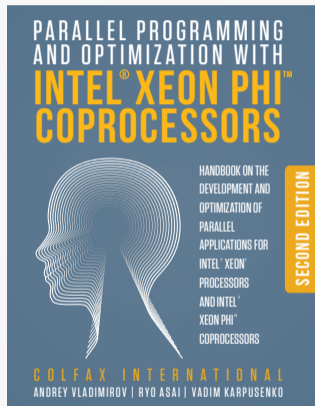

<http://xeonphi.com/book>

COLFAX RESEARCH  
CONTRIBUTING TO INNOVATIONS IN COMPUTING

READ WATCH LEARN CONNECT JOIN

To search, type and hit enter

**Popular**

**The Hands-On Tutorials (HOT) webinars: details on efficient programming for Intel architecture**

**The Hands-On Workshop (HOW) Series**

**Introduction to Intel DAAL, Part 1: Polynomial Regression with Batch Mode Computation**

**Parallel Programming Book**

Introduction to parallel programming, deep discussion of optimization techniques, exercises.  
© 2015, Colfax International, 508 pages.

**Research and Educational Publications**

**Introduction to Intel DAAL, Part 1: Polynomial Regression with Batch Mode Computation**

**Optimization Techniques for the Intel MIC Architecture, Part 3 of 3: False Sharing and Padding**

**Software Developer's Introduction to the HGST Ultrastar Archive Hato SMR Drives**

**Optimization Techniques for the Intel MIC Architecture, Part 2 of 3: Strip-Mining for Vectorization**

**Optimization Techniques for the Intel MIC Architecture, Part 1 of 3: Multi-Threading and Parallel Reduction**

**Performance to Power and Performance to Cost Ratios with Intel Xeon Phi Coprocessors (and why ix Acceleration May Be Enough)**

**Featured Video**

See Research material on vectorization in a streaming code

**Events**

**Presentations**

**Cardview**

**Consulting**

Colfax offers consulting services for enterprises, research help you:

- Optimize your existing application to take advantage of parallelism, from vectors to cores to clusters and...
- Future-proof your application for upcoming innovations.
- Accelerate your application using coprocessor technology.
- Investigate the potential system configurations that satisfy your cost, power, performance requirements.
- Take a clean slate to develop a novel approach to reduce your computing pro...

**Episode 2.1 — Purpose of the MIC architecture**

**Software Developer's Introduction to the HGST Ultrastar Archive Hato SMR Drives**

**Configuration and Benchmarks of Peer-to-Peer Communication over Gigabit Ethernet and InfiniBand in a Cluster with Intel Xeon Phi Coprocessors**

**Fluid Dynamics with Fortran on Intel Xeon Phi coprocessors**

**Interview with James Reinders: future of Intel MIC architecture, parallel programming, education**

<http://colfaxresearch.com/>