



PROGRAMMING AND OPTIMIZATION FOR INTEL[®] ARCHITECTURE

One-Day Workshop

Andrey Vladimirov and Ryo Asai
Colfax International — colfaxresearch.com

July 2017

WELCOME

While best efforts have been used in preparing this training, Colfax International makes no representations or warranties of any kind and assumes no liabilities of any kind with respect to the accuracy or completeness of the contents and specifically disclaims any implied warranties of merchantability or fitness of use for a particular purpose. The publisher shall not be held liable or responsible to any person or entity with respect to any loss or incidental or consequential damages caused, or alleged to have been caused, directly or indirectly, by the information or programs contained herein. No warranty may be created or extended by sales representatives or written sales materials.

Labs:

```
~> git clone https://github.com/ColfaxResearch/HOW-Series-Labs.git
```

Slides:

<https://colfaxresearch.com/events/>



§1. SNEAK PEAK



AGENDA AND WHAT'S IN IT FOR YOU

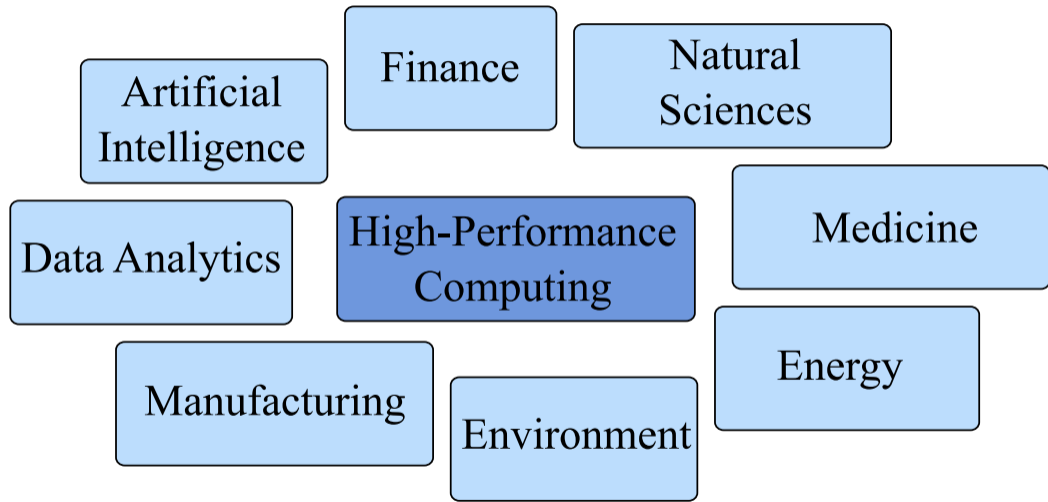

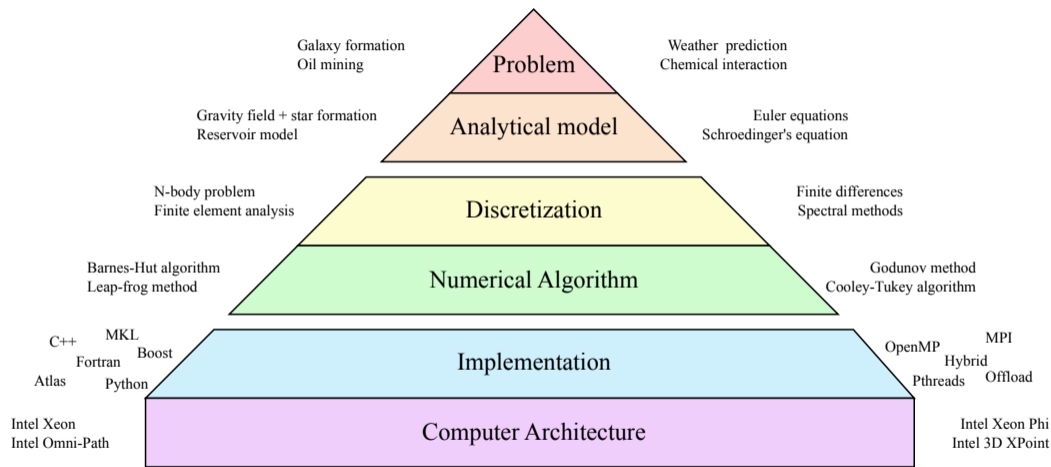

40 YEARS OF MICROPROCESSOR DATA

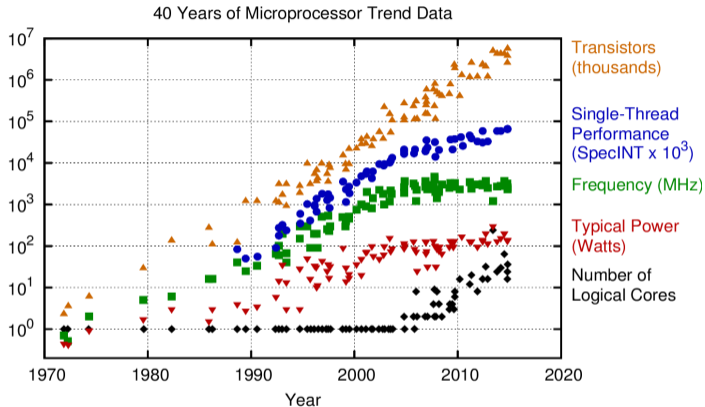

Original data up to the year 2010 collected and plotted by M. Horowitz, F. Labonte, O. Shacham, K. Olukotun, L. Hammond, and C. Batten
 New plot and data collected for 2010-2015 by K. Rupp

Source: karlrupp.net

Code Modernization

Optimizing software to better utilize features available in modern computer architectures.

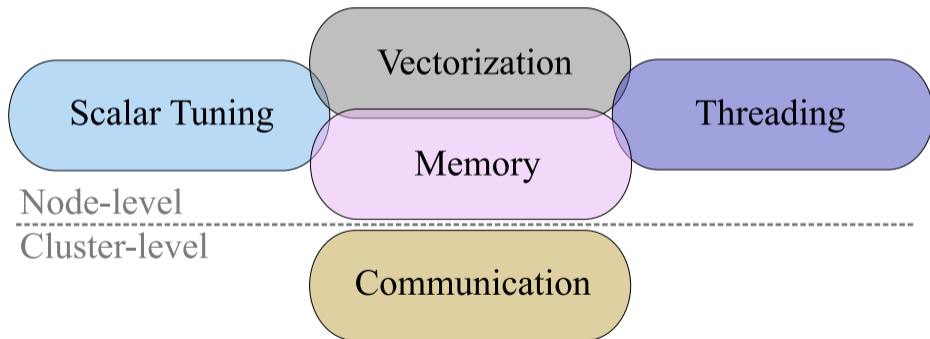

PROGRAMMING MODEL CONTINUITY

Common story for many applications:

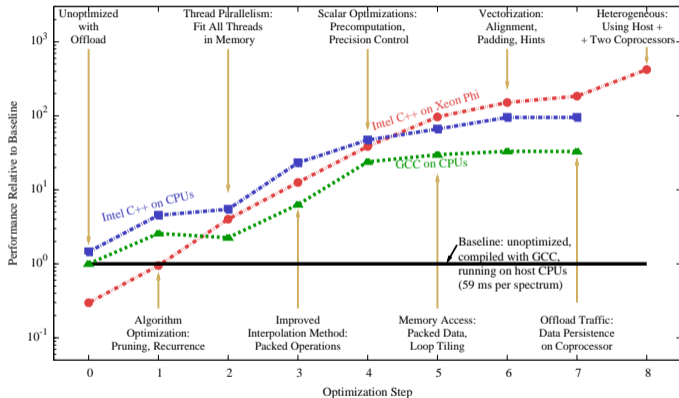

(see <http://xeonphi.com/papers/heatcode>)

§2. PROGRAMMING, OPTIMIZATION BY EXAMPLE



DIRECT N-BODY SIMULATION

Gravitational N-body dynamics:

Newton's law of universal gravitation:

$$M_i \vec{R}_i''(t) = G \sum_j \frac{M_i M_j}{|\vec{R}_i - \vec{R}_j|^3} (\vec{R}_j - \vec{R}_i)$$

where:

$$|\vec{R}_i - \vec{R}_j| = \sqrt{(R_{i,x} - R_{j,x})^2 + (R_{i,y} - R_{j,y})^2 + (R_{i,z} - R_{j,z})^2}$$

particles are attracted to each other
with the gravitational force

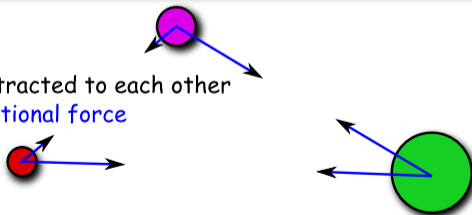

APPLICATION

1. Astrophysics:

- planetary systems
- galaxies
- cosmological structures

2. Electrostatic systems:

- molecules
- crystals

This work: “toy model” with all-to-all $O(n^2)$ algorithm. Practical N-body simulations may use tree algorithms with $O(n \log n)$ complexity.



Source: [APOD](#), credit: Debra Meloy Elmegreen (Vassar College) et al., & the Hubble Heritage Team (AURA/ STScI/ NASA)

ALL-TO-ALL APPROACH ($O(n^2)$ COMPLEXITY SCALING)

Each particle is stored as a structure:

```
1 struct ParticleType {  
2     float x, y, z;  
3     float vx, vy, vz;  
4 };
```

main() allocates an array of ParticleType:

```
1 ParticleType* particle = new ParticleType[nParticles];
```

Particle propagation step is timed:

```
1 const double tStart = omp_get_wtime(); // Start timing  
2 MoveParticles(nParticles, particle, dt);  
3 const double tEnd = omp_get_wtime(); // End timing
```

PARTICLE UPDATE ENGINE

```
1 void MoveParticles(int nParticles, ParticleType* particle, float dt) {
2     for (int i = 0; i < nParticles; i++) { // Particles that experience force
3         float Fx = 0, Fy = 0, Fz = 0; // Gravity force on particle i
4         for (int j = 0; j < nParticles; j++) { // Particles that exert force
5             // Newton's law of universal gravity
6             const float dx = particle[j].x - particle[i].x;
7             const float dy = particle[j].y - particle[i].y;
8             const float dz = particle[j].z - particle[i].z;
9             const float drSquared = dx*dx + dy*dy + dz*dz + 1e-20;
10            const float drPower32 = pow(drSquared, 3.0/2.0);
11            // Calculate the net force
12            Fx += dx/drPower32; Fy += dy/drPower32; Fz += dz/drPower32;
13        }
14        // Accelerate particles in response to the gravitational force
15        particle[i].vx+=dt*Fx; particle[i].vy+=dt*Fy; particle[i].vz+=dt*Fz;
16    }
```



INTEL ARCHITECTURE

Intel Xeon Processor



Current: Broadwell
Upcoming: Skylake

Multi-Core Architecture

Intel Xeon Phi Coprocessor, 1st generation

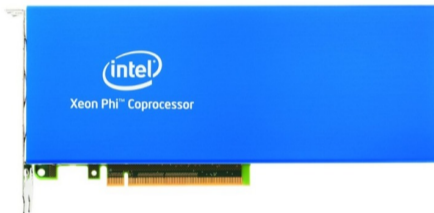

Knights Corner (KNC)

Intel Xeon Phi Processor, 2nd generation*



* socket and coprocessor versions

Knights Landing (KNL)

Intel Many Integrated Core (MIC) Architecture



- C/C++/Fortran
- Linux/Windows
- ≤ 3 TiB DDR4
- ≤ 44 cores (2-way)
- ≈ 3 GHz
- 2 HT/core
- 256-bit AVX

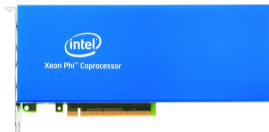

- C/C++/Fortran
- Special Linux
- ≤ 16 GiB GDDR5
- 57-61 cores
- ≈ 1.2 GHz
- 4 HW THR/core
- 512-bit IMCI



- C/C++/Fortran
- Linux
- MCDRAM+DDR4
- 64-72 cores
- 1.3-1.5 GHz
- 4 HT/core
- 512-bit AVX-512

INTEL XEON PHI PROCESSORS (2ND GEN)

- ▶ Specialized for floating-point computing
- ▶ Highly-parallel (72 cores*)
- ▶ Balanced for compute
- ▶ Less forgiving than Xeon
- ▶ Theor. ~ 3.0 TFLOP/s in DP*
- ▶ Meas. ~ 490 GB/s bandwidth*

* Intel Xeon Phi processor, Knights Landing architecture (2016), top-of-the-line (e.g., 7290P)

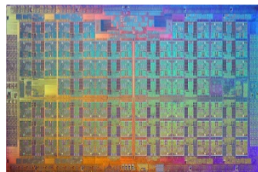
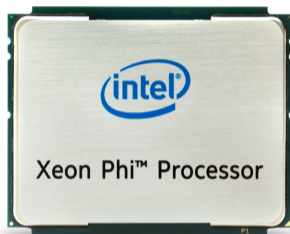

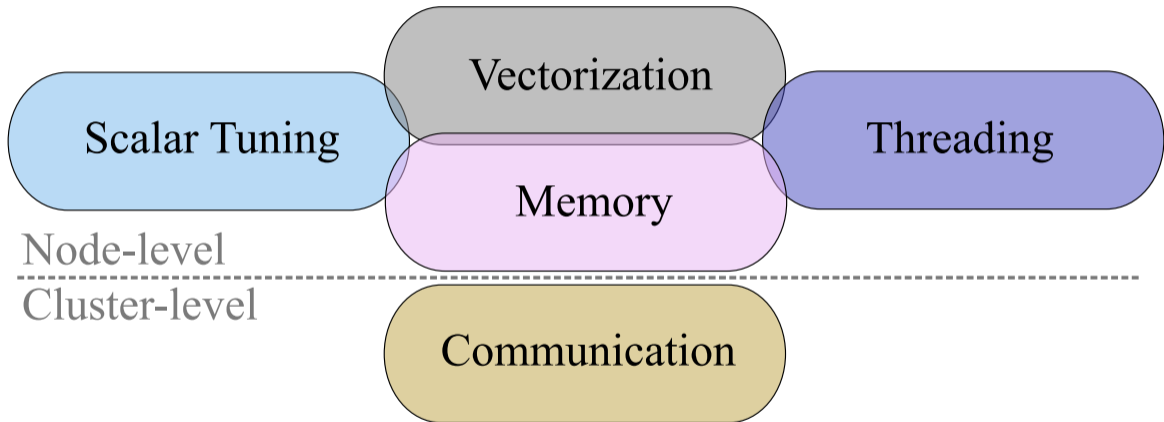



TASK PARALLELISM

THREADS VERSUS PROCESSES

Option 1: Partitioning data set between threads/processes

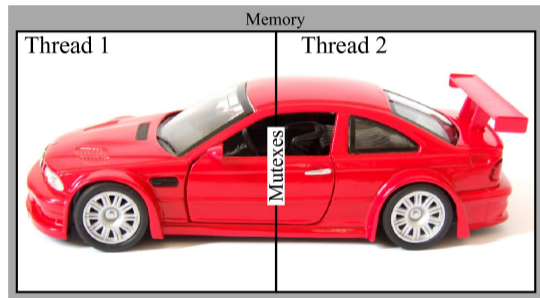
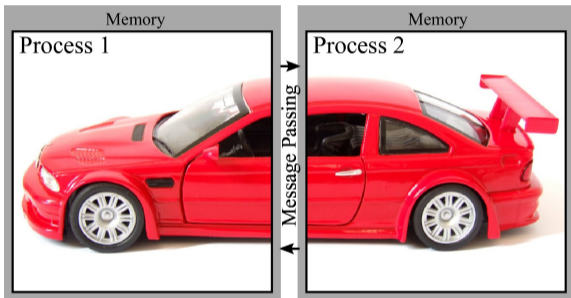

Examples: computational fluid dynamics (CFD), image processing.

THREADS VERSUS PROCESSES

Option 2: Sharing data set between threads/processes

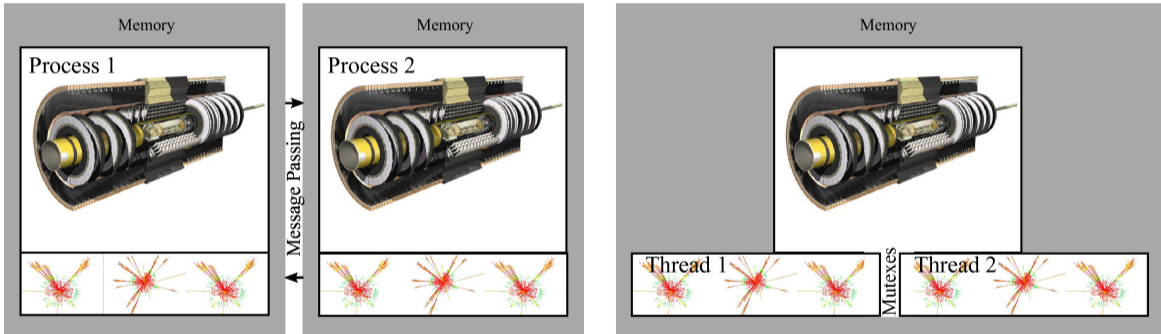

Examples: particle transport simulation, machine learning (inference).

THREADING FRAMEWORKS

Framework	Functionality
C++11 Threads	Asynchronous functions; only C++
POSIX Threads	Fork/join; C/C++/Fortran; Linux
Cilk Plus	Async tasks, loops, reducers, load balance; C/C++
TBB	Trees of tasks, complex patterns; only C++
OpenMP	Tasks, loops, reduction, load balancing, affinity, nesting, C/C++/Fortran (+SIMD, offload)

PARALLEL PATTERNS

Common parallel patterns call for collective communication

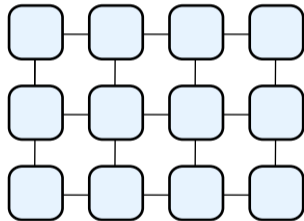
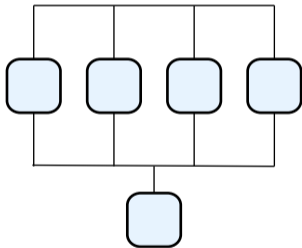
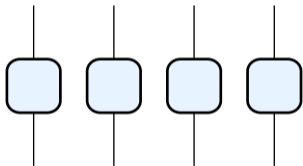

"HELLO WORLD" OPENMP PROGRAM

```
1  #include <omp.h>
2  #include <stdio.h>
3
4  int main(){
5      // This code is executed by 1 thread
6      const int nt=omp_get_max_threads();
7      printf("OpenMP with %d threads\n", nt);
8
9      #pragma omp parallel
10     { // This code is executed in parallel
11       // by multiple threads
12       printf("Hello World from thread %d\n",
13             omp_get_thread_num());
14     }
15 }
```

- ▶ OpenMP = “Open Multi-Processing” = computing-oriented framework for shared-memory programming
- ▶ Threads – streams of instructions that share memory address space
- ▶ Distribute threads across CPU cores for parallel speedup

COMPILING THE "HELLO WORLD" OPENMP PROGRAM

```
vega@lyra% icpc -qopenmp hello_omp.cc
vega@lyra% export OMP_NUM_THREADS=5
vega@lyra% ./a.out
OpenMP with 5 threads
Hello World from thread 0
Hello World from thread 3
Hello World from thread 1
Hello World from thread 2
Hello World from thread 4
```

OMP_NUM_THREADS controls number of OpenMP threads (default: logical CPU count)

CONTROL OF VARIABLE SHARING

Method 1: using clauses in pragma omp parallel (C, C++, Fortran):

```
1 int A, B; // Variables declared at the beginning of a function
2 #pragma omp parallel private(A) shared(B)
3 {
4     // Each thread has its own copy of A, but B is shared
5 }
```

Method 2: using scoping (only C and C++):

```
1 int B; // Variable declared outside of parallel scope - shared by default
2 #pragma omp parallel
3 {
4     int A; // Variable declared inside the parallel scope - always private
5     // Each thread has its own copy of A, but B is shared
6 }
```

LOOP-CENTRIC PARALLELISM: FOR-LOOPS IN OPENMP

- ▶ Simultaneously launch multiple threads
- ▶ Scheduler assigns loop iterations to threads
- ▶ Each thread processes one iteration at a time

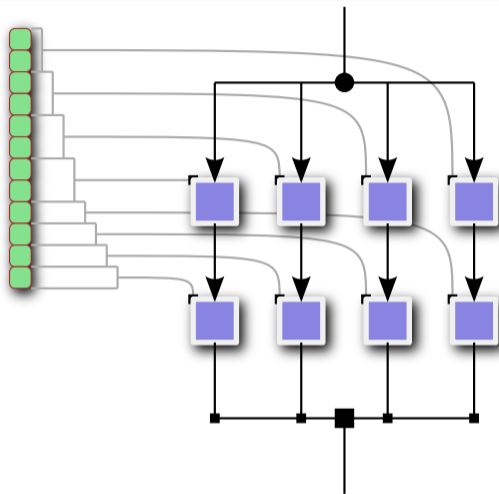

Parallelizing a for-loop.

LOOP-CENTRIC PARALLELISM: FOR-LOOPS IN OPENMP

The OpenMP library will distribute the iterations of the loop following the `#pragma omp parallel for` across threads.

```
1  #pragma omp parallel for  
2  for (int i = 0; i < n; i++) {  
3      printf("Iteration %d is processed by thread %d\n",  
4          i, omp_get_thread_num());  
5      // ... iterations will be distributed across available threads...  
6  }
```

LOOP-CENTRIC PARALLELISM: FOR-LOOPS IN OPENMP

```
1  #pragma omp parallel
2  {
3      // Code placed here will be executed by all threads.
4
5      // Alternative way to specify private variables:
6      // declare them in the scope of pragma omp parallel
7      int private_number=0;
8
9  #pragma omp for
10     for (int i = 0; i < n; i++) {
11         // ... iterations will be distributed across available threads...
12     }
13     // ... code placed here will be executed by all threads
14 }
```

LOOP SCHEDULING MODES IN OPENMP

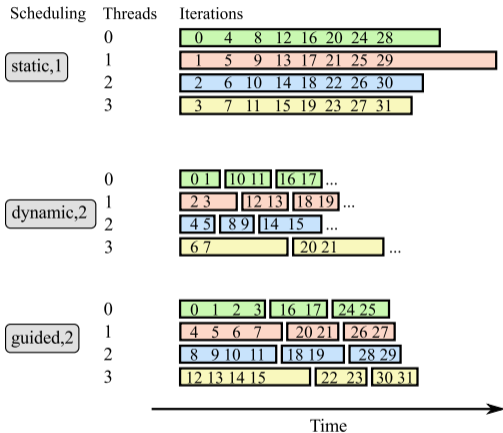
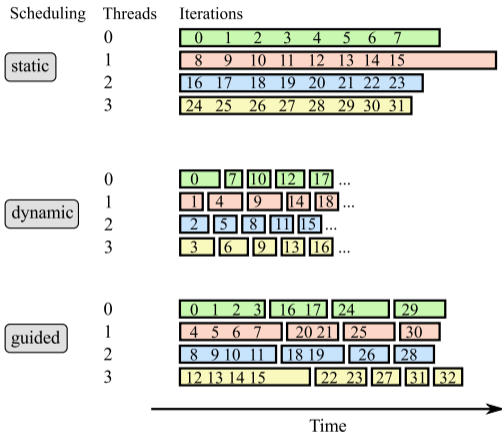

FORK-JOIN MODEL OF PARALLEL EXECUTION

- ▶ Each thread can spawn daughter threads
- ▶ Available threads pick up queued tasks
- ▶ Expresses algorithms that cannot be expressed in the loop model (e.g., parallel recursion)

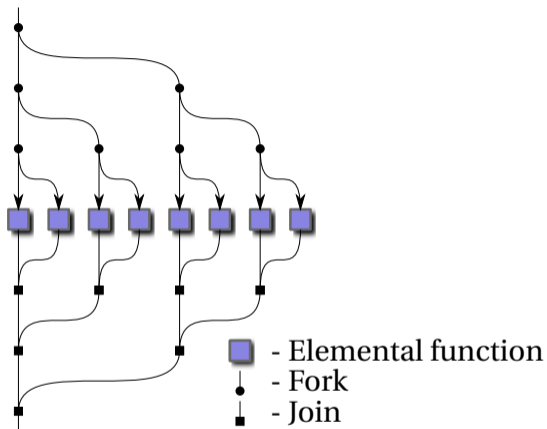

Fork-join model of parallel execution.

(#pragma omp task functionality)

TASKS IN OPENMP: EXAMPLE

```

1 // Starting the first task:
2 #pragma omp parallel
3 { // Enter a parallel region
4 #pragma omp single
5   { // Start the first task
6     // from only one thread
7     RecursiveWorkload(args);
8   }
9 }

```

```

1 // Recursive task spawning:
2 void RecursiveWorkload(Arg* args) {
3   if (args->size > threshold) {
4     // Split work
5     Arg* args1=args->FirstHalf();
6     Arg* args2=args->SecondHalf();
7
8     // Parallel divide-and-conquer
9     #pragma omp task firstprivate(args1)
10    { RecursiveWorkload(args1); }
11    #pragma omp task firstprivate(args2)
12    { RecursiveWorkload(args2); }
13  } else {
14    // End of recursion
15    args->ProcessSmallestSubTask();
16  }
17 }

```

INCORPORATING THREAD PARALLELISM

Before:

```
1  for (int i = 0; i < nParticles; i++) { // Particles that experience force
2  float Fx = 0, Fy = 0, Fz = 0; // Gravity force on particle i
3  for (int j = 0; j < nParticles; j++) { // Particles that exert force
4  // Newton's law of universal gravity
5  ...
```

After:

```
1  #pragma omp parallel for
2  for (int i = 0; i < nParticles; i++) { // Particles that experience force
3  float Fx = 0, Fy = 0, Fz = 0; // Gravity force on particle i
4  for (int j = 0; j < nParticles; j++) { // Particles that exert force
5  // Newton's law of universal gravity
6  ...
```



SCALAR OPTIMIZATION

IMPROVING SCALAR EXPRESSIONS

Before:

```
1  const float drSquared = dx*dx + dy*dy + dz*dz + 1e-20;  
2  const float drPower32 = pow(drSquared, 3.0/2.0);  
3  // Calculate the net force  
4  Fx += dx/drPower32;  Fy += dy/drPower32;  Fz += dz/drPower32;
```

After:

```
1  const float drRecip    = 1.0f/sqrtf(dx*dx + dy*dy + dz*dz + 1e-20);  
2  const float drPowerN32 = drRecip*drRecip*drRecip;  
3  // Calculate the net force  
4  Fx += dx*drPowerN32;  Fy += dy*drPowerN32;  Fz += dz*drPowerN32;
```

- ▶ Strength reduction (division → multiplication by reciprocal)
- ▶ Precision control (suffix `-f` on single-precision constants and functions)
- ▶ Reliance on hardware-supported reciprocal square root

PRECISION CONTROL FOR TRANSCENDENTAL FUNCTIONS

- `-fimf-precision=value[:funclist]` Defines the precision for math functions. `value` is one of: `high`, `medium` or `low`
- `-fimf-max-error=ulps[:funclist]` The maximum allowable error expressed in ulps (*units in last place*)
- `-fimf-accuracy-bits=n[:funclist]` The number of correct bits required for mathematical function accuracy.
- `-fimf-domain-exclusion=n[:funclist]` Defines a list of special-value numbers that do not need to be handled.
`int n` derived by the bitwise OR of types:
extremes: 1, NaNs: 2, infinities: 4, denormals¹: 8, zeroes: 16.

¹by default, on Intel Xeon Phi, denormals are flushed to zero in hardware, but supported in SVMML

FLOATING-POINT SEMANTICS

The Intel C++ Compiler may represent floating-point expressions in executable code differently, depending on the *floating-point semantics*.

<code>-fp-model strict</code>	Only value-safe optimizations
<code>-fp-model precise</code>	calculations are reproducible from run to run exceptions controlled using <code>-fp-model except</code> (default)
<code>-fp-model fast=1</code>	Value-unsafe optimizations are allowed
<code>-fp-model fast=2</code>	better performance at the cost of lower accuracy
<code>-fp-model source</code>	Intermediate arithmetic results are rounded to the precision defined in the source code.
<code>-fp-model double</code>	Intermediate arithmetic results are rounded to 53-bit (double) precision.
<code>-fp-model extended</code>	Intermediate arithmetic results are rounded to 64-bit (extended) precision.
<code>-fp-model [no-]except</code>	controls floating-point exception semantics.



DATA PARALLELISM

SHORT VECTOR SUPPORT

Vector instructions – one of the implementations of SIMD (Single Instruction Multiple Data) parallelism.

Scalar Instructions

$$\begin{array}{r} 4 + 1 = 5 \\ 0 + 3 = 3 \\ -2 + 8 = 6 \\ 9 + -7 = 2 \end{array}$$

Vector Instructions

$$\begin{array}{r} 4 \\ 0 \\ -2 \\ 9 \end{array} + \begin{array}{r} 1 \\ 3 \\ 8 \\ -7 \end{array} = \begin{array}{r} 5 \\ 3 \\ 6 \\ 2 \end{array}$$

Vector Length

SIMULTANEOUS THREADING AND VECTORIZATION

This approach often works:

```
1 #pragma omp parallel for
2 for (int i = 0; i < n; i++) // Thread parallelism in outer loop
3 #pragma simd
4   for (int j = 0; j < m; j++) // Vectorization in inner loop
5     DoSomeWork(A[i][j]);
```

That works as well:

```
1 #pragma omp parallel for simd
2 for (int i = 0; i < n; i++) // If the problem is all data-parallel
3   DoSomeWork(A[i]);
```

INSTRUCTION SETS IN INTEL ARCHITECTURE

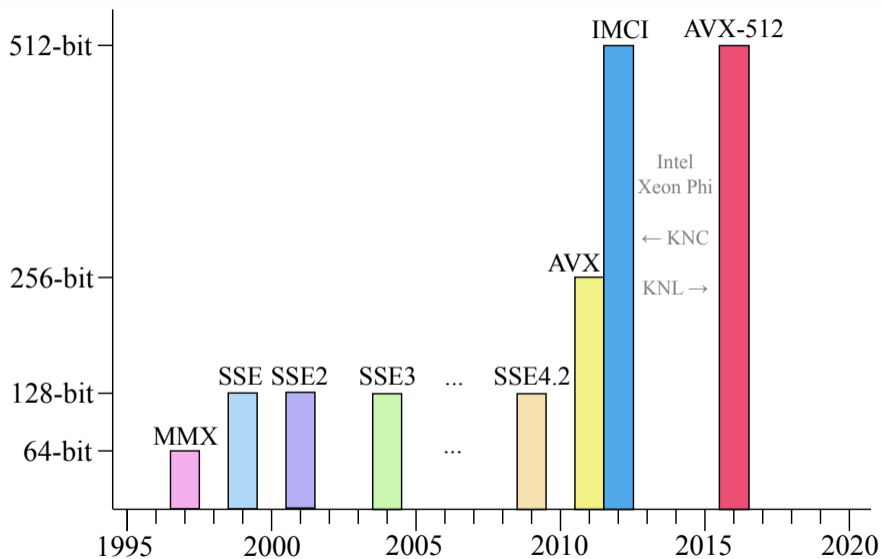

<https://software.intel.com/sites/landingpage/IntrinsicsGuide>

The Intel Intrinsics Guide is an interactive reference tool for Intel intrinsic instructions, which are C style functions that provide access to many Intel instructions - including Intel® SSE, AVX, AVX-512, and more - without the need to write assembly code.

- MMX
- SSE
- SSE2
- SSE3
- SSSE3
- SSE4.1
- SSE4.2
- AVX
- AVX2
- FMA
- AVX-512
- KNC
- SVML
- Other

- Application-Targeted
- Arithmetic
- Bit Manipulation
- Cast
- Compare
- Convert
- Cryptography
- Elementary Math Functions
- General Support

__m128i_mm_add_epi16 (__m128i a, __m128i b) paddw

__m128i_mm_add_epi32 (__m128i a, __m128i b) paddq

__m128i_mm_add_epi64 (__m128i a, __m128i b) paddq

__m128i_mm_add_epi8 (__m128i a, __m128i b) paddb

__m128d_mm_add_pd (__m128d a, __m128d b) addpd

Synopsis

```
__m128d_mm_add_pd (__m128d a, __m128d b)
#include "emmintrin.h"
Instruction: addpd xmm, xmm
CPUID Flags: SSE2
```

Description

Add packed double-precision (64-bit) floating-point elements in a and b, and store the results in dst.

Operation

```
FOR j := 0 to 1
  i := j*64
  dst[i+63:i] := a[i+63:i] + b[i+63:i]
ENDFOR
```

Performance

Architecture	Latency	Throughput
Haswell	3	0.8
Ivy Bridge	3	1

DETECTING AVAILABLE INSTRUCTIONS

In the OS:

```
[student@cdt ~]% cat /proc/cpuinfo
...
fpu_exception   : yes
cpuid level     : 11
wp              : yes
flags           : fpu vme de pse tsc msr pae mce
cx8 apic mtrr pge mca cmov pat pse36 clflush mmx
fxsr sse sse2 ss ht syscall nx lm constant_tsc
unfair_spinlock pni ssse3 cx16 sse4_1 sse4_2
x2apic popcnt aes hypervisor lahf_lm fsgsbase
bogomips       : 5985.17
clflush size   : 64
cache_alignment: 64
address sizes  : 46 bits physical, 48 bits virtual
...
```

In code (see also):

```
1 // Intel compiler
2 // preprocessor macros:
3
4 #ifdef __SSE__
5 // ...SSE code path
6 #endif
7
8 #ifdef __SSE4_2__
9 // ...SSE code path
10 #endif
11
12 #ifdef __AVX__
13 // ...AVX code path
14 #endif
```

AUTOMATIC VECTORIZATION OF LOOPS

```

1  #include <stdio>
2
3  int main(){
4      const int n=1024;
5      int A[n] __attribute__((aligned(64)));
6      int B[n] __attribute__((aligned(64)));
7
8      for (int i = 0; i < n; i++)
9          A[i] = B[i] = i;
10
11     // This loop will be auto-vectorized
12     for (int i = 0; i < n; i++)
13         A[i] = A[i] + B[i];
14
15     for (int i = 0; i < n; i++)
16         printf("%2d %2d %2d\n",i,A[i],B[i]);
17 }

```

```

vega@lyra% icpc autovec.cc -qopt-report
vega@lyra% cat autovec.optrpt
...
LOOP BEGIN at autovec.cc(12,3)
remark #15399: vectorization support:
unroll factor set to 2 [autovec.cc(12,3)]
remark #15300: LOOP WAS VECTORIZED
[autovec.cc(12,3)]
LOOP END
...
vega@lyra% ./a.out
0 0 0
1 2 1
2 4 2
3 6 3
4 8 4
...

```

LIMITATIONS ON AUTOMATIC VECTORIZATION

- ▶ Innermost loops*
- ▶ Known number of iterations
- ▶ No vector dependence
- ▶ Functions must be SIMD-enabled

* `#pragma omp simd` to override

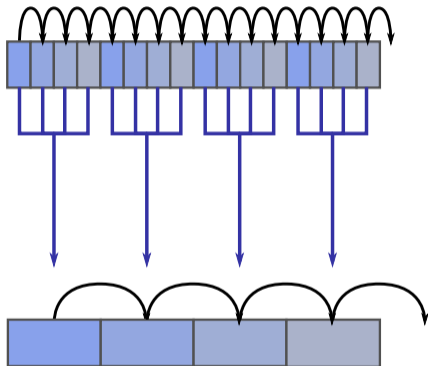

VECTORIZE MORE LOOPS: `#pragma omp simd`

Used to “enforce vectorization of loops”, which includes:

- ▶ Loops with SIMD-enabled functions
- ▶ Second innermost loops
- ▶ Failed vectorization due to compiler decision
- ▶ Where guidance is required (vector length, reduction, etc.)

See OpenMP reference for syntax; similar to Intel's `#pragma simd`

VECTORIZING WITH UNIT-STRIDE MEMORY ACCESS

Before:

```
1 struct ParticleType {
2     float x, y, z, vx, vy, vz;
3 }; // ...
4     const float dx = particle[j].x - particle[i].x;
5     const float dy = particle[j].y - particle[i].y;
6     const float dz = particle[j].z - particle[i].z;
```

After:

```
1 struct ParticleSet {
2     float *x, *y, *z, *vx, *vy, *vz;
3 }; // ...
4     const float dx = particle.x[j] - particle.x[i];
5     const float dy = particle.y[j] - particle.y[i];
6     const float dz = particle.z[j] - particle.z[i];
```

WHY AOS TO SOA CONVERSION HELPS: UNIT STRIDE

Array of Structures
(sub-optimal)

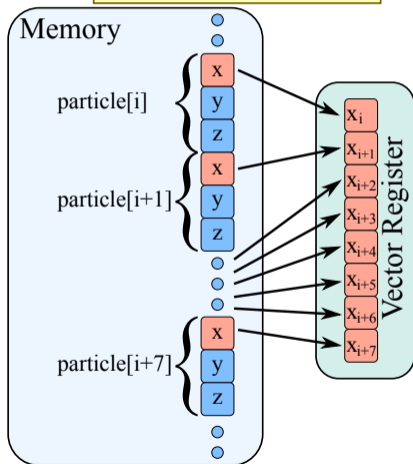

Structure of Arrays
(optimal)

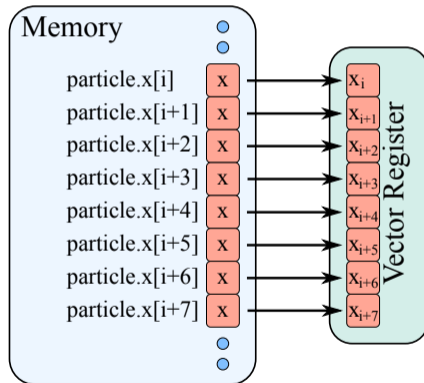



MEMORY OPTIMIZATION

INTEL XEON CPU: MEMORY ORGANIZATION

- ▶ Hierarchical cache structure
- ▶ Two-way processors have NUMA architecture

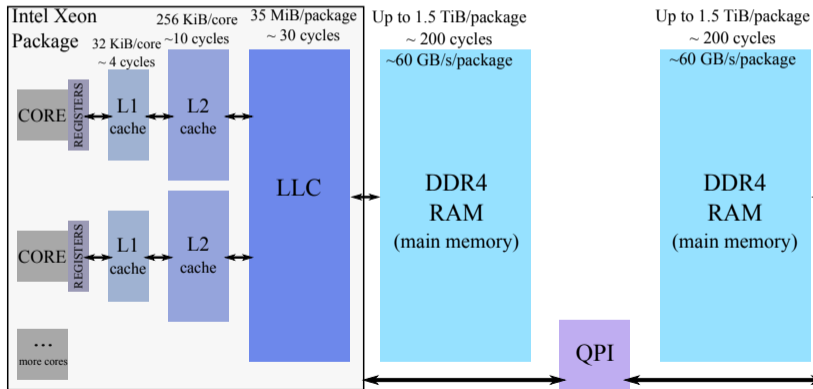

KNL MEMORY ORGANIZATION (BOOTABLE)

- ▶ On-package high-bandwidth memory (HBM) – MCDRAM
- ▶ Optimized for arithmetic performance and bandwidth (not latency)

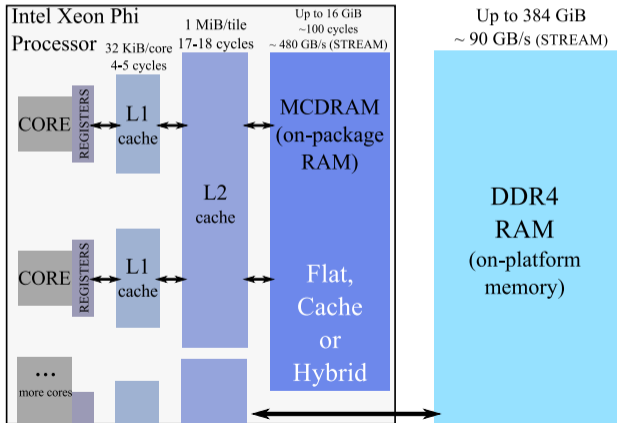
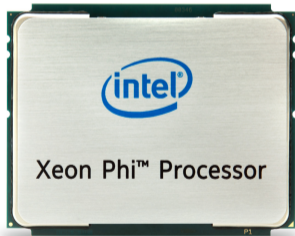

LOOP TILING

Original:

```
for (i=0; i<m; i++)
  for (j=0; j<n; j++)
    ...=...*b[j];
```

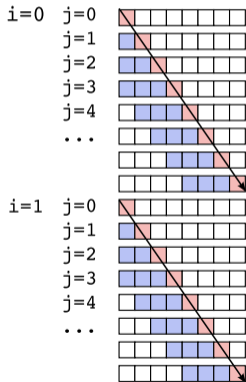

- - cached, LRU eviction policy
- - cache miss (read from memory, slow)
- - cache hit (read from cache, fast)

Cache size: 4

TILE=4

(must be tuned to cache size)

Cache hit rate without tiling: 0%

Cache hit rate with tiling: 50%

Tiled:

```
for (jj=0; jj<n; jj+=TILE)
  for (i=0; i<m; i++)
    for (j=jj; j<jj+TILE; j++)
      ...=...*b[j];
```

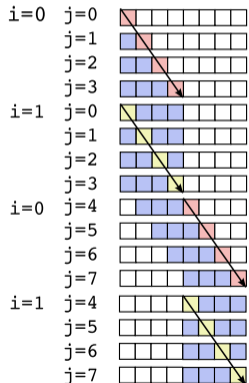

IMPROVING CACHE TRAFFIC

Before:

```

1  for (int i = 0; i < nParticles; i++) { // Particles that experience force
2  float Fx = 0, Fy = 0, Fz = 0; // Gravity force on particle i
3  for (int j = 0; j < nParticles; j++) { // Particles that exert force
4  // ...
5  Fx += dx*drPowerN32; Fy += dy*drPowerN32; Fz += dz*drPowerN32;

```

After: (tileSize = 16)

```

1  for (int ii = 0; ii < nParticles; ii += tileSize) { // Particle blocks
2  float Fx[tileSize], Fy[tileSize], Fz[tileSize]; // Force on particle block
3  Fx[:] = Fy[:] = Fz[:] = 0;
4  #pragma unroll(tileSize)
5  for (int j = 0; j < nParticles; j++) { // Particles that exert force
6  for (int i = ii; i < ii + tileSize; i++) { // Traverse the block
7  // ...
8  Fx[i-ii] += dx*drPowerN32; Fy[i-ii] += dy*drPowerN32; Fz[i-ii] += dz*drPowerN32;

```

IMPACT OF CODE OPTIMIZATION

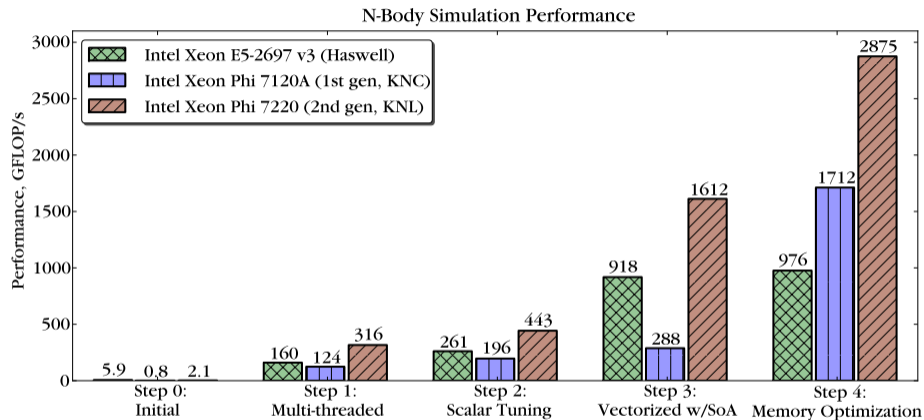

Contributed as Chapter 23 in “[Intel Xeon Phi Processor High Performance Programming, Knights Landing Edition](#)” (2016)



§3. OPTIMIZATION POINTERS

SCOPE OF THIS COURSE

Areas of code optimization for Intel architecture:

1. **Scalar optimization** (compiler-friendly practices)
2. **Vectorization** (must use 16- or 8-wide vectors)
3. **Multi-threading** (must scale to 100+ threads)
4. **Memory access** (streaming access or tiling)
5. **Communication** (offload, MPI traffic control)



SCALAR TUNING

OPTIMIZATION LEVEL

Default optimization level -O2

- ▶ optimization for speed
- ▶ automatic vectorization
- ▶ inlining
- ▶ constant propagation
- ▶ dead-code elimination
- ▶ loop unrolling

Optimization level -O3

- ▶ aggressive optimization
- ▶ loop fusion
- ▶ block-unroll-and-jam
- ▶ if-statement collapse
- ▶ *may or may not be better than -O2*

SETTING OPTIMIZATION LEVEL

For the entire file:

```
vega@lyra% icpc -o mycode -O3 source.cc
```

For a specific function:

```
1 #pragma intel optimization_level 3
2 void my_function() {
3     //...
4 }
```

STRENGTH REDUCTION

Common Subexpression Elimination.

```

1  for (int i = 0; i < n; i++) {
2      A[i] /= B;
3  }
```

```

1  const float Br = 1.0f/B;
2  for (int i = 0; i < n; i++)
3      A[i] *= Br;
```

Replace division with multiplication.

```

1  for (int i = 0; i < n; i++) {
2      P[i] = (Q[i]/R[i])/S[i];
3  }
```

```

1  for (int i = 0; i < n; i++) {
2      P[i] = Q[i]/(R[i]*S[i]);
3  }
```

Use functions with Hardware support.

```

1  double r = pow(r2, -0.5);
2  double v = exp(x);
3  double y = y0*exp(log(x/x0)*
4              log(y1/y0)/log(x1/x0));
```

```

1  double r = 1.0/sqrt(r2);
2  double v = exp2(x*1.44269504089);
3  double y = y0*exp2(log2(x/x0)*
4              log2(y1/y0)/log2(x1/x0));
```

CONSISTENCY OF PRECISION: CONSTANTS

```
1 // Bad: 2 is "int"
2 long b=a*2;
3
4 // Bad: overflow
5 long n=100000*100000;
6
7 // Bad: excessive
8 float p=6.283185307179586;
9
10 // Bad: 2 is "int"
11 float q=2*p;
12
13 // Bad: 1e9 is "double"
14 float r=1e9*p;
15
16 // Bad: 1 is "int"
17 double t=s+1;
```

```
1 // Good: 2L is "long"
2 long b=a*2L;
3
4 // Good: correct
5 long n=100000L*100000L;
6
7 // Good: accurate
8 float p=6.283185f;
9
10 // Good: 2.0f is "float"
11 float q=2.0f*p;
12
13 // Good: 1e9f is "float"
14 float r=1e9f*p;
15
16 // Good: 1.0 is "double"
17 double t=s+1.0;
```

CONSISTENCY OF PRECISION: FUNCTIONS

```
1 // Bad: 3.14 is a double
2 float x = 3.14;
3
4 // Bad: sin() is a
5 // double precision function
6 float s = sin(x);
7
8 // Bad: round() takes double
9 // and returns double
10 long v = round(x);
11
12 // Bad: abs() is not from IML
13 // it takes int and returns int
14 int v = abs(x);
```

```
1 // Good: 3.14f is a float
2 float x = 3.14f;
3
4 // Good: sin() is a
5 // single precision function
6 float s = sinf(x);
7
8 // Good: lroundf() takes float
9 // and returns long
10 long v = lroundf(x);
11
12 // Good: fabsf() is from IML
13 // It takes and returns a float
14 float v = fabsf(x);
```

MOVE BRANCHES OUTSIDE OF LOOPS

```
1 // Elegant, but bad for performance
2 for (i = 0; i < n; i++) {
3     if (i == 0) {
4         // Absorbing boundary
5         B[i] = 0.0;
6     } else if (i == n - 1) {
7         // Injection at boundary
8         B[i] = A[i] + 1.0;
9     } else {
10        // Diffusion between boundaries
11        B[i] = 0.25*(A[i-1] +
12                    2.0*A[i] + A[i+1]);
13    }
14 }
```

```
1 // Moving branches out of loops
2
3
4 // Absorbing boundary
5 B[i] = 0.0;
6
7 for (i = 1; i < n - 1; i++) {
8     // Diffusion between boundaries
9     B[i] = 0.25*(A[i-1] + 2.0*A[i] +
10                 A[i+1]);
11 }
12
13 // Injection at boundary
14 B[n-1] = A[n-1] + 1.0;
```

REDUNDANT CODE IS OK

```
1 // Elegant, but bad for performance
2 for (ii = 0; ii < n; ii+=16) {
3     for (i = ii; i < ii+16; i++)
4         // Branch causes unnecessary
5         // masking of vector iterations
6         if (i < n) {
7             A[k*n + i] = ...
8         }
9 }
```

```
1 // Redundant code, but faster
2 const int nTrunc = n - n%16;
3 for (ii = 0; ii < nTrunc; ii+=16) {
4     for (i = ii; i < ii+16; i++)
5         A[k*n + i] = ...
6
7     for (i = nTrunc; i < n; i++)
8         A[k*n + i] = ...
9 }
```



VECTORIZATION

AUTOMATIC VECTORIZATION OF LOOPS

```

1  #include <stdio>
2
3  int main(){
4      const int n=1024;
5      int A[n] __attribute__((aligned(64)));
6      int B[n] __attribute__((aligned(64)));
7
8      for (int i = 0; i < n; i++)
9          A[i] = B[i] = i;
10
11     // This loop will be auto-vectorized
12     for (int i = 0; i < n; i++)
13         A[i] = A[i] + B[i];
14
15     for (int i = 0; i < n; i++)
16         printf("%2d %2d %2d\n",i,A[i],B[i]);
17 }

```

```

vega@lyra% icpc autovec.cc -qopt-report
vega@lyra% cat autovec.optrpt
...
LOOP BEGIN at autovec.cc(12,3)
remark #15399: vectorization support:
unroll factor set to 2 [autovec.cc(12,3)]
remark #15300: LOOP WAS VECTORIZED
[autovec.cc(12,3)]
LOOP END
...
vega@lyra% ./a.out
0 0 0
1 2 1
2 4 2
3 6 3
4 8 4
...

```

VECTORIZE MORE LOOPS: `#pragma omp simd`

Used to “enforce vectorization of loops”, which includes:

- ▶ Loops with SIMD-enabled functions
- ▶ Second innermost loops
- ▶ Failed vectorization due to compiler decision
- ▶ Where guidance is required (vector length, reduction, etc.)

See OpenMP reference for syntax; similar to Intel's `#pragma simd`

SIMD-ENABLED FUNCTIONS

Define function in one file (e.g., library), use in another

```
1 // Compiler will produce 3 versions:
2 #pragma omp declare simd
3 float my_simple_add(float x1, float x2){
4     return x1 + x2;
5 }
```

```
1 // May be in a separate file
2 #pragma omp simd
3 for (int i = 0; i < N, ++i) {
4     output[i] = my_simple_add(inputa[i], inputb[i]);
5 }
```

SIMD-ENABLED FUNCTIONS

The solution is to design and declare the function as *SIMD-enabled*:

```
1 __attribute__((vector)) float my_simple_add(float x1, float x2) {  
2     return x1 + x2;  
3 }
```

When using SIMD-enabled functions, use `#pragma simd`.

```
1 // ...in a separate source file:  
2 #pragma simd  
3 for (int i = 0; i < N, ++i) {  
4     output[i] = my_simple_add(inputa[i], inputb[i]);  
5 }
```

In this case, automatic vectorization succeeds.

AUTO-VECTORIZED LOOPS MAY BE COMPLEX)

```
1  for (int i = ii; i < ii + tileSize; i++) { // Auto-vectorized
2
3  // Newton's law of universal gravity
4  const float dx = particle.x[j] - particle.x[i]; // x[j] is a const
5  const float dy = particle.y[j] - particle.y[i]; // x[i] -> vector
6  const float dz = particle.z[j] - particle.z[i];
7  const float rr = 1.0f/sqrtf(dx*dx + dy*dy + dz*dz + softening);
8  const float drPowerN32 = rr*rr*rr;
9
10 // Calculate the net force
11 Fx[i-ii] += dx * drPowerN32;
12 Fy[i-ii] += dy * drPowerN32;
13 Fz[i-ii] += dz * drPowerN32;
14 }
```

AUTO-VECTORIZED LOOPS MAY BE COMPLEX (EXAMPLE 2)

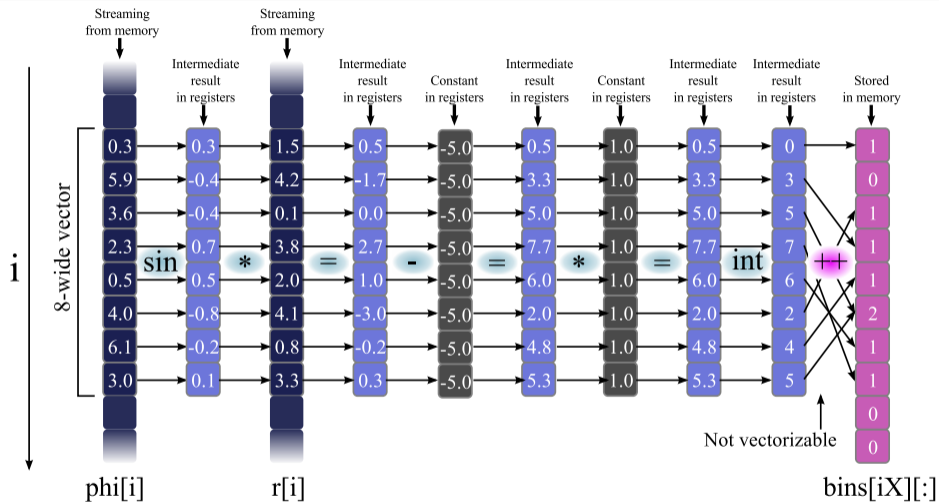

See [this paper](#) for more details

ASSUMED VECTOR DEPENDENCE

- ▶ True vector dependence – vectorization impossible:

```

1 float *a, *b;
2 for (int i = 1; i < n; i++)
3     a[i] += b[i]*a[i-1]; // dependence on the previous element

```

- ▶ Assumed vector dependence – compiler suspects dependence

```

1 void mycopy(int n,
2             float* a, float* b) {
3     for (int i=0; i<n; i++)
4         a[i] = b[i];
5 }

```

```

vega@lyra% icpc -c vdep.cc -qopt-report
vega@lyra% cat vdep.optrpt
...
remark #15304: loop was not
vectorized: non-vectorizable loop
instance from multiversioning
...

```

IGNORING ASSUMED VECTOR DEPENDENCE

To ignore assumed vector dependence

```
#pragma ivdep
```

```
1 void mycopy(int n,  
2     float* a, float* b) {  
3     pragma ivdep  
4     for (int i=0; i<n; i++)  
5         a[i] = b[i];  
6 }
```

```
vega@lyra% icpc -c vdep.cc -qopt-report  
vega@lyra% cat vdep.optrpt  
...  
LOOP BEGIN at vdep.cc(4,1)  
<Multiversed v2>  
remark #15300: LOOP WAS VECTORIZED  
LOOP END
```

MULTIVERSIONING

```
user@host% icpc -c code.cc -qopt-report
user@host% cat code.optrpt
...
LOOP BEGIN at code.cc(4,1)
<Multiversiomed v1>
    remark #25228: LOOP WAS VECTORIZED
LOOP END
...
LOOP BEGIN at code.cc(4,1)
<Multiversiomed v2>
    remark #15304: loop was not vectorized: non-vectorizable loop instance ....
LOOP END
```

Pointers checked for aliasing *runtime* to choose code path.

POINTER DISAMBIGUATION TO PREVENT MULTIVERSIONING

Prevent multiversioning by using `#pragma ivdep`

```
1 #pragma ivdep  
2   for (int i = 0; i < n; i++)  
3     // ...
```

```
user@host% icpc -c code.cc -qopt-report -qopt-report-phase:vec  
user@host% cat vdep.optrpt  
...  
LOOP BEGIN at code.cc(4,1)  
    remark #25228: LOOP WAS VECTORIZED  
LOOP END  
...
```

Alternative: keyword `restrict` – more fine-grained, weaker.

UNIT-STRIDE ACCESS

Unit-stride access is optimal:

```
1 for (int i = 0; i < n; i++)
2   A[i] += B[i];
```

Non-unit stride is slower:

```
1 for (int i = 0; i < n; i++)
2   A[i*stride] += B[i];
```

Stochastic access may be vectorized (but not efficient):

```
1 for (int i = 0; i < n; i++)
2   A[offset[i]] += B[i];
```

It may be a question of changing the order of loop nesting, but sometimes you need to modify data structures:

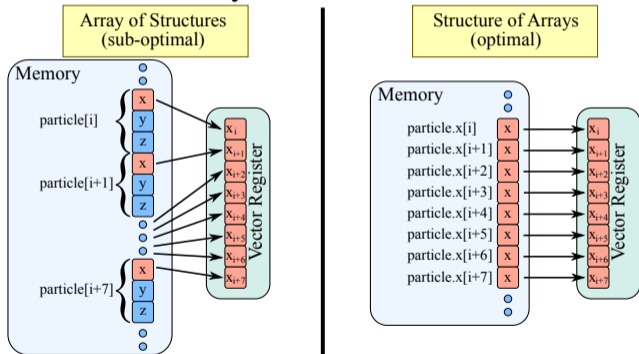

DATA ALIGNMENT REQUIREMENTS

Array `char* p` is `n`-byte aligned if `((size_t)p%n==0)`.

Processor	Operation	Alignment
Xeon (Westmere and earlier)	SSE load, store	16-byte
Xeon (Sandy Bridge and later)	AVX load, store	32-byte (relaxed)
Xeon Phi (1st gen)	IMCI load, store	64-byte (strict)
Xeon Phi (1st gen)	DMA transfer in offload	4096-byte (preferred)
Xeon Phi (2nd gen)	AVX-512 load, store	64-byte (relaxed)

Why align: speed up vector load/stores, avoid false sharing, accelerate RDMA.

WHAT HAPPENS WITHOUT ALIGNMENT

Compiler may implement peel and remainder loops:

```
for (i = 0; i < n; i++) A[i] = ...
```

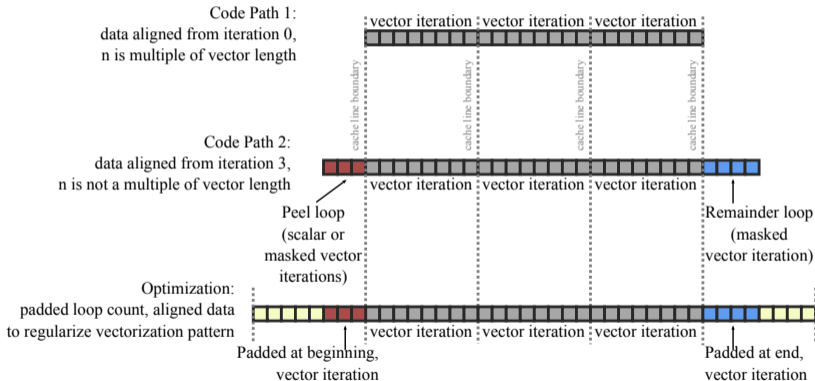

CREATING ALIGNED DATA CONTAINERS

▷ Data alignment on the stack

```
1 float A[n] __attribute__((aligned(64))); // 64-byte alignment applied
```

▷ Data alignment on the heap

```
1 float *A = (float*) _mm_malloc(sizeof(float)*n, 64);
```

- ▷ A[0] is aligned on a 64-byte boundary.
- ▷ Very high alignment value may lead to wasted virtual memory.
- ▷ Fortran: directive or compiler argument `-align array64byte`

PADDING MULTI-DIMENSIONAL CONTAINERS FOR ALIGNMENT

To use aligned instructions, you may need to pad inner dimension of multi-dimensional arrays to a multiple of 16 (in SP) or 8 (DP) elements.

Incorrect:

```
1 // A - matrix of size (n x n)
2 // n is not a multiple of 16
3 float* A =
4   _mm_malloc(sizeof(float)*n*n, 64);
5
6 for (int i = 0; i < n; i++)
7     // A[i*n + 0] may be unaligned
8     for (int j = 0; j < n; j++)
9         A[i*n + j] = ...
```

Correct:

```
1 // ... Padding inner dimension
2 int lda=n + (16-n%16); // lda%16==0
3 float* A =
4   _mm_malloc(sizeof(float)*n*lda, 64);
5
6 for (int i = 0; i < n; i++)
7     // A[i*lda + 0] aligned for any i
8     for (int j = 0; j < n; j++)
9         A[i*lda + j] = ...
```

VECTORIZATION DIRECTIVES

- ▷ `#pragma simd`
- ▷ `#pragma vector always`
- ▷ `#pragma vector aligned | unaligned`
- ▷ `__assume_aligned` keyword
- ▷ `#pragma vector nontemporal | temporal`
- ▷ `#pragma novector`
- ▷ `#pragma ivdep`
- ▷ `restrict` qualifier and `-restrict` command-line argument
- ▷ `#pragma loop count`



MULTI-THREADING

INSUFFICIENT PARALLELISM

Analysis in Intel VTune Amplifier XE

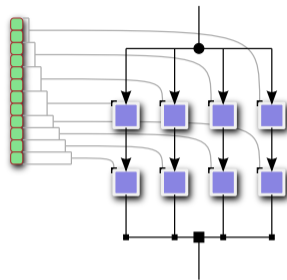
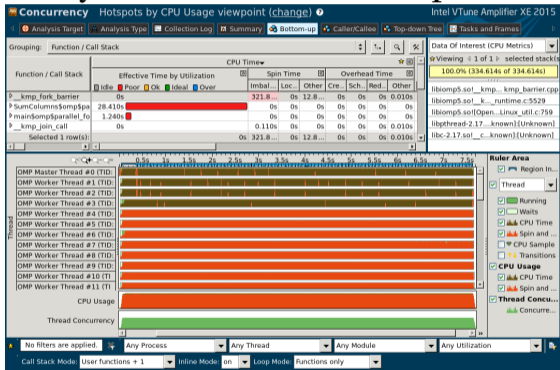

- ▶ Occurs when there are not enough iterations or parallel work-items exposed to the parallel loop in OpenMP.

EXAMPLE: DEALING WITH INSUFFICIENT PARALLELISM

$$S_i = \sum_{j=0}^n M_{ij}, i = 0 \dots m. \quad (1)$$

- ▶ $m=4$ is small, smaller than the number of threads in the system
- ▶ $n \approx 10^8$ is large enough so that matrix does not fit into cache

```

1 void sum_unoptimized(const int m, const int n, long* M, long* s){
2   #pragma omp parallel for
3     for (int i=0; i<m; i++) { // m=4
4       long total=0;
5       #pragma vector aligned
6         for (int j=0; j<n; j++) // n=100000000
7           total+=M[i*n+j];
8       s[i]=total; }

```

EXPOSING PARALLELISM: STRIP-MINING AND LOOP COLLAPSE

```
1 void sum_stripmine(const int m, const int n, long* M, long* s){
2     const int STRIP=1024;
3     assert(n%STRIP==0);
4     s[0:m]=0;
5     #pragma omp parallel
6     {
7         long total[m];    total[0:m]=0;
8     #pragma omp for collapse(2) schedule(guided)
9         for (int i=0; i<m; i++)
10            for (int jj=0; jj<n; jj+=STRIP)
11    #pragma vector aligned
12                for (int j=jj; j<jj+STRIP; j++)
13                    total[i]+=M[i*n+j];
14        for (int i=0; i<m; i++)                // Reduction
15    #pragma omp atomic
16            s[i]+=total[i];
17    } }
```

EXPOSING PARALLELISM: STRIP-MINING AND LOOP COLLAPSE

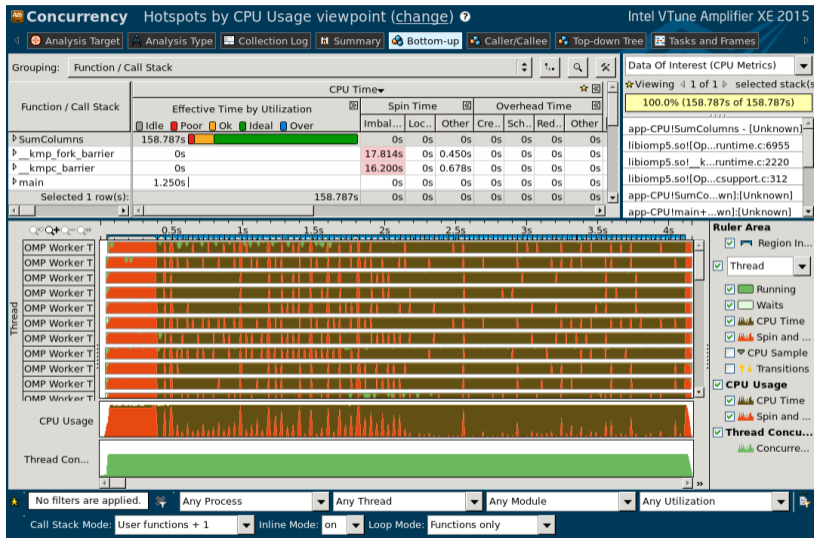

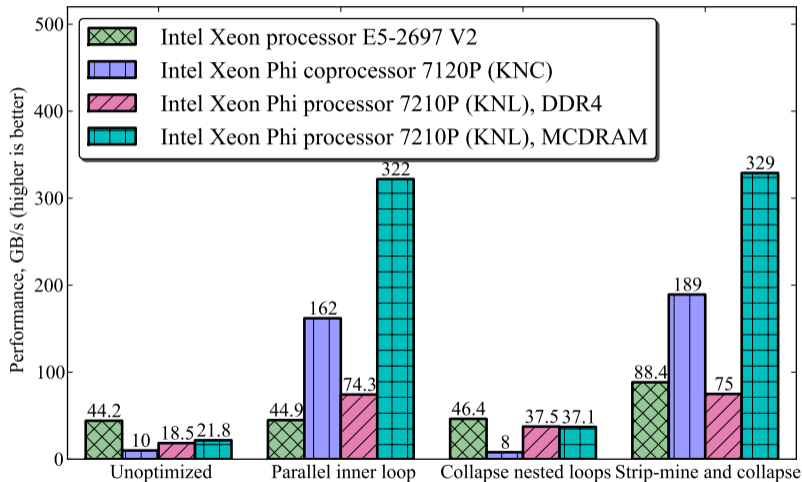

RACE CONDITIONS AND UNPREDICTABLE PROGRAM BEHAVIOR

```

1  #include <omp.h>
2  #include <stdio>
3  int main() {
4      const int n = 1000;
5      int total = 0;
6      #pragma omp parallel for
7      for (int i = 0; i < n; i++) {
8          total = total + i; // Race condition
9      }
10     printf("total=%d (must be %d)\n", total,
11            ((n-1)*n)/2);
12 }

```

```

vega@lyra% icpc -o app omp-race.cc -qopenmp
vega@lyra% ./app
total=208112 (must be 499500)

```

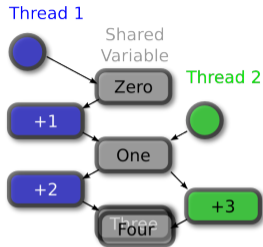

Race Condition!

- Occurs when 2 or more threads access the same memory address, and at least one of these accesses is for writing

AVOIDING RACES WITH THREAD-PRIVATE STORAGE

Correct and efficient code:

```

1  int total = 0;
2  #pragma omp parallel
3  {
4      int total_thr = 0;
5      #pragma omp for
6      for (int i=0; i<n; i++)
7          total_thr += i;
8
9      #pragma omp atomic
10     total += total_thr;
11
12 }

```

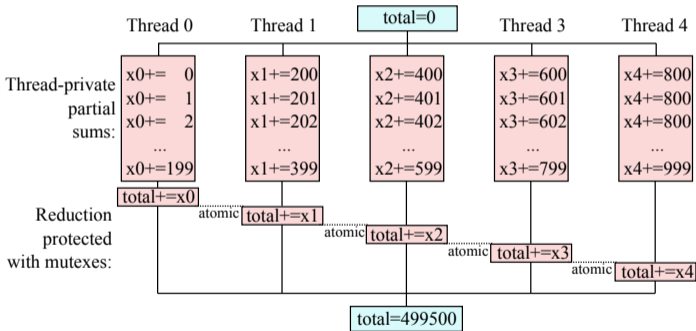

EXAMPLE: BINNING PROBLEM

```

1 void Histogram(
2     // Ages, values from 0.0f to 100.0f:
3     const float* age,
4     // Size of array age, n=100000000:
5     const int n,
6     // Output: counts in groups:
7     int* const hist,
8     // Size of array hist, m=5:
9     const int m,
10    const float grpWidth) {
11    for (int i = 0; i < n; i++) {
12        const int j = int(age[i]/grpWidth);
13        hist[j]++;
14    }
15 }

```

- ▶ Vector dependence in `hist[j]++`
- ▶ Strip-mine or use conflict detection

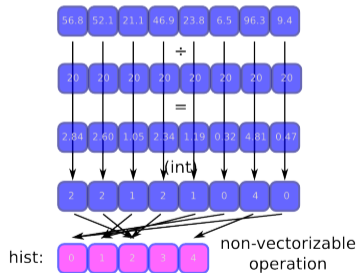

USING REDUCTION INSTEAD OF SYNCHRONIZATION

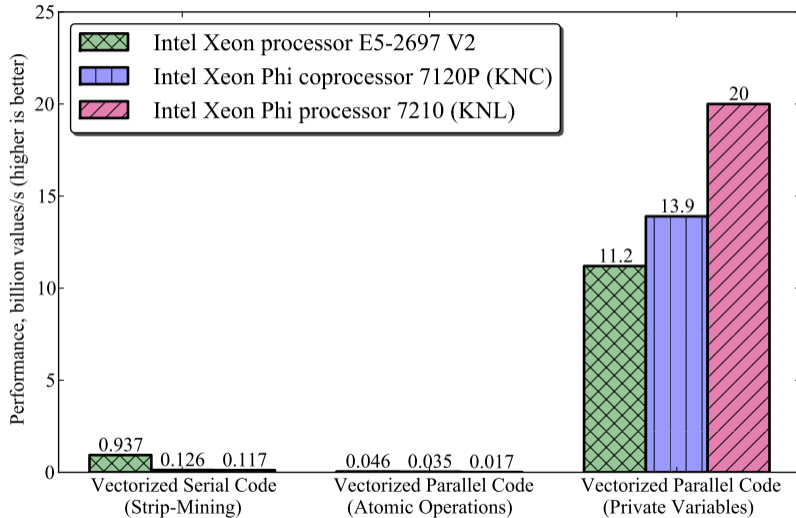

FALSE SHARING. DATA PADDING AND PRIVATE VARIABLES

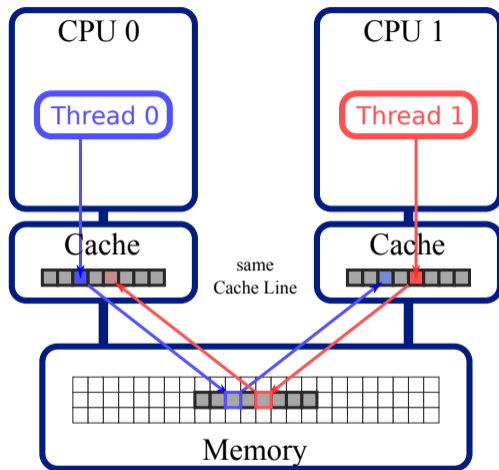

- ▶ Occurs when 2 or more threads access the same cache line, and at least one of the accesses is for writing
- ▶ Caused by *coherent caches*
- ▶ Cache line is 64-byte wide (in modern Intel architectures)

PADDING TO AVOID FALSE SHARING

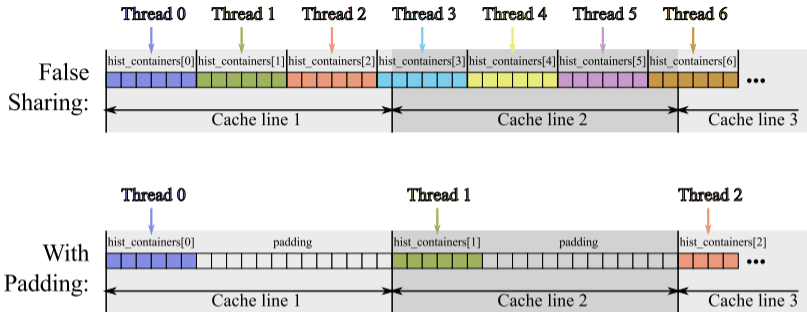

```

1 // Padding to avoid sharing a cache line between threads
2 const int paddingBytes = 64;
3 const int paddingElements = paddingBytes / sizeof(int);
4 const int mPadded = m + (paddingElements - m % paddingElements);
5 int hist_containers[nThreads][mPadded]; // New container

```

PADDING TO AVOID FALSE SHARING

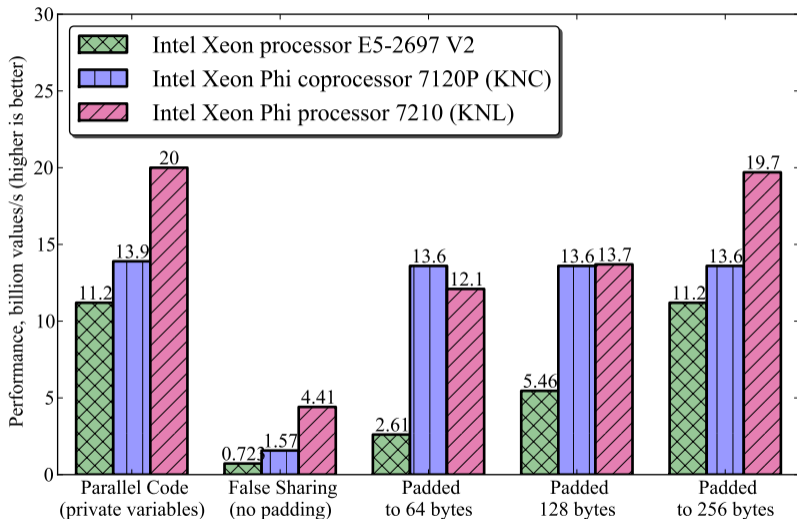

LOOP SCHEDULING MODES IN OPENMP

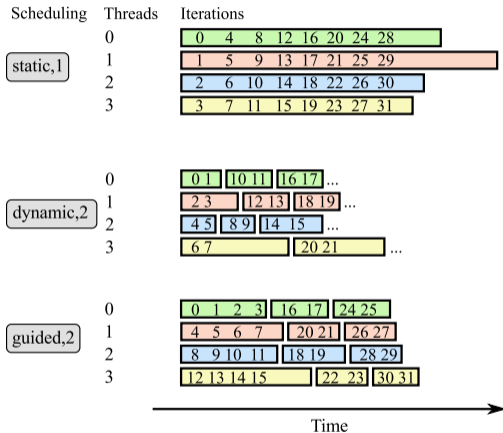
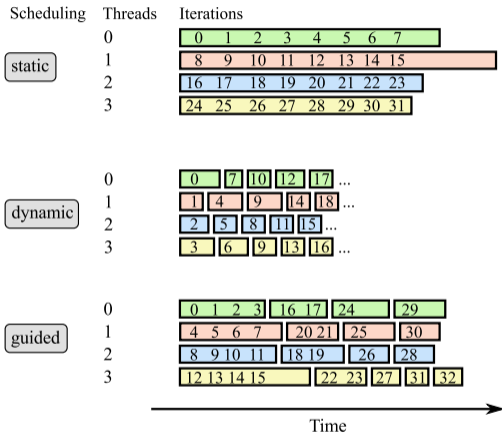

WHAT IS THREAD AFFINITY

- ▶ OpenMP threads may migrate between cores
- ▶ Forbid migration — improve locality — increase performance
- ▶ Affinity patterns “scatter” and “compact” may improve cache sharing, relieve thread contention

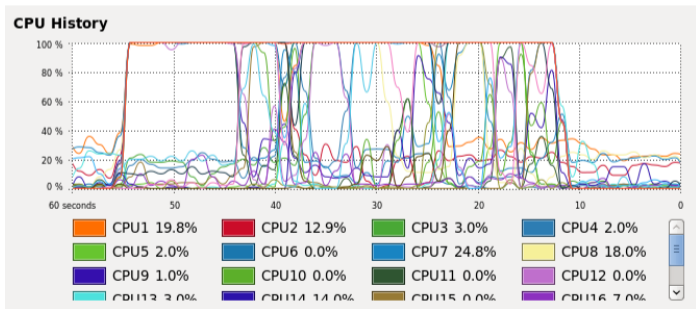

NESTED PARALLELISM WITH OPENMP

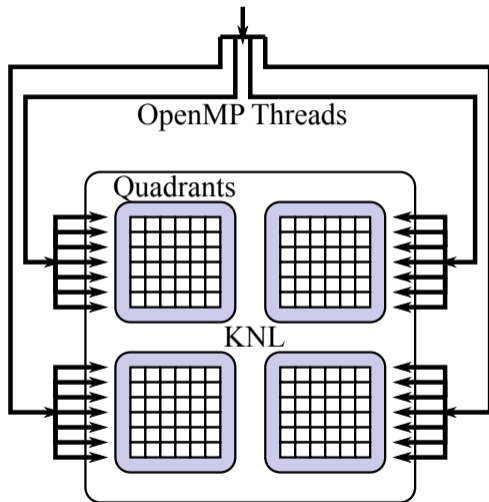

```
1  #pragma omp parallel
2  {
3  #pragma omp parallel
4  {
5      // ...
6  }
7  }
```

- ▶ Tune granularity of parallelism
- ▶ Improve resource sharing in NUMA systems



CACHE AND MEMORY ACCESS

HOW CHEAP ARE FLOPS?

Theoretical estimates, Intel Xeon E5-2697 V3 processor

Performance = 28 cores \times 2.7 GHz \times (256/64) vec.lanes \times 2 FMA \times 2 FPU \approx 1.2 TFLOP/s

Required Data Rate = 1.2 TFLOP/s \times 8 bytes \approx 10 TB/s

Memory Bandwidth = $\eta \times 2 \times 59.7 \approx$ 0.1 TB/s

Ratio = 10/0.1 \approx 100 (FLOPs)/(Memory Access)

If the Arithmetic Intensity is...

- ▶ > 100 (FLOPs)/(Memory Access) — Compute Bound Application
- ▶ < 100 (FLOPs)/(Memory Access) — Bandwidth Bound Application

ON COMPUTATIONAL COMPLEXITY OF ALGORITHMS

Type	Properties	Examples
$O(N)$	Each data element is used a fixed number of times. Memory-bound unless the number of times is large.	Array scaling, image brightness adjustment, vector dot-product.
$O(N^\alpha)$	Each element is used $N^{\alpha-1}$ times. A lot of data reuse for $\alpha > 1$. Good implementation can be compute-bound, poor one – memory-bound.	Matrix-matrix multiplication: $O(N^{3/2})$ (N = amount of data in matrix), direct N-body calculation: $O(N^2)$
$O(N \log N)$	Each element is used $\log N$ times. For small problems – memory-bound, for very large problems transitions to compute-bound	Fast Fourier transform, merge sort
$O(\log N)$	Always memory-bound.	Binary search

N = data size

ARITHMETIC INTENSITY AND ROOFLINE MODEL

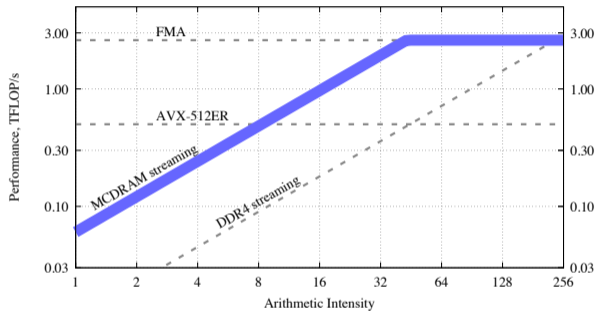

More on roofline model: [Williams et al.](#)

STREAMING VERSUS RANDOM ACCESS

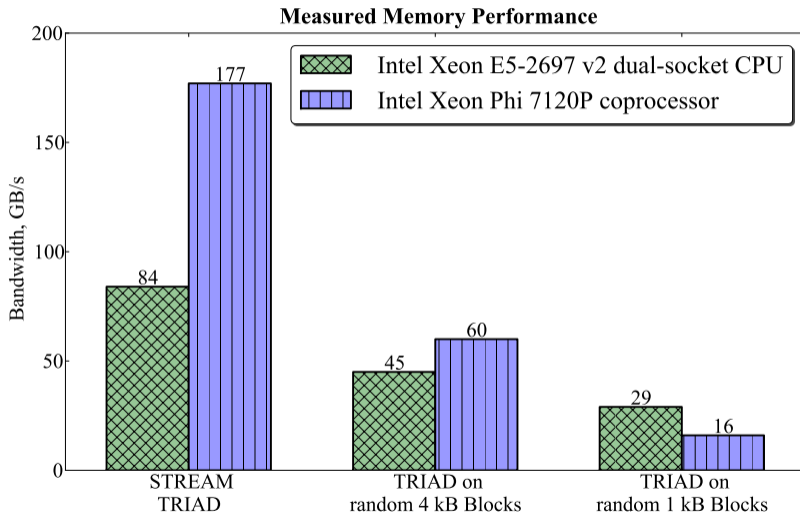

PRINCIPLE

Choose loop order to maintain unit-stride memory access

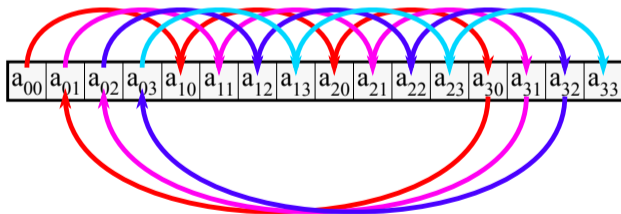
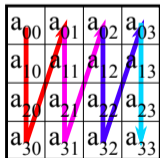
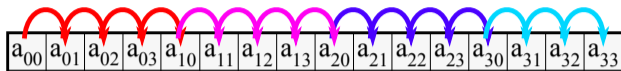
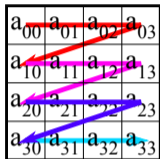

Compiler may or may not be able to automate loop permutation.

EXAMPLE: OVER-SIMPLIFIED MATRIX-MATRIX MULTIPLICATION

$$C = AB \quad \Leftrightarrow \quad C_{ij} = \sum_{k=0}^{n-1} A_{ik}B_{kj}$$

Before:

```

1  #pragma omp parallel for
2  for (int i = 0; i < n; i++)
3      for (int j = 0; j < n; j++)
4      #pragma vector aligned
5          for (int k = 0; k < n; k++)
6              C[i*n+j] += A[i*n+k]*B[k*n+j];

```

After:

```

1  #pragma omp parallel for
2  for (int i = 0; i < n; i++)
3      for (int k = 0; k < n; k++)
4      #pragma vector aligned
5          for (int j = 0; j < n; j++)
6              C[i*n+j] += A[i*n+k]*B[k*n+j];

```

NUMA ARCHITECTURES

NUMA = Non-Uniform Memory Access. Cores have fast access to local memory, slow access to remote memory.

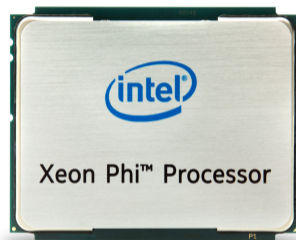
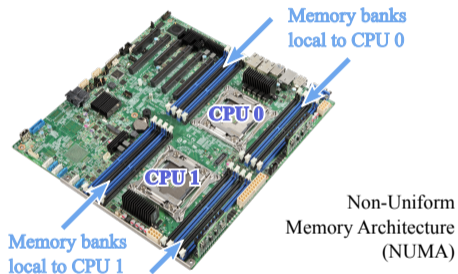

Examples:

- ▶ Multi-socket Intel Xeon processors
- ▶ Second generation Intel Xeon Phi in **sub-NUMA clustering mode**

ALLOCATION ON FIRST TOUCH

- ▶ Memory allocation occurs not during `_mm_malloc()`, but upon the first write to the buffer (“first touch”)
- ▶ Default NUMA allocation policy is “on first touch”
- ▶ For better performance in NUMA systems, initialize data with the same parallel pattern as during data usage

```
1 float* A = (float*)_mm_malloc(n*m*sizeof(float), 64);  
2  
3 // Initializing from parallel region for better performance  
4 #pragma omp parallel for  
5 for (int i = 0; i < n; i++)  
6     for (int j = 0; j < m; j++)  
7         A[i*m + j] = 0.0f;
```

FIRST-TOUCH ALLOCATION POLICY

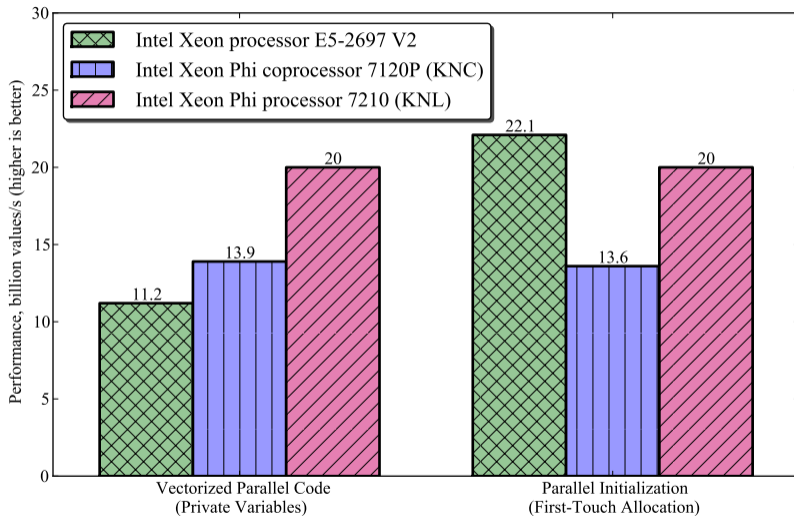

PRINCIPLE

- ▶ The order of nested loops must be chosen for best locality of data access
- ▶ At -O2 and above, the compiler automatically interchanges loops in some cases
- ▶ In other cases, loop interchange must be investigated manually

LOOP FUSION TECHNIQUE

Re-use data in cache by fusing loops in a data processing pipeline

```
1 MyDataType* data = new MyDataType(n);
2
3 for (int i = 0; i < n; i++)
4     Initialize(data[i]);
5
6 for (int i = 0; i < n; i++)
7     Stage1(data[i]);
8
9 for (int i = 0; i < n; i++)
10    Stage2(data[i]);
```

```
1 MyDataType* data = new MyDataType(n);
2
3 for (int i = 0; i < n; i++) {
4
5     Initialize(data[i]);
6
7     Stage1(data[i]);
8
9     Stage2(data[i]);
10 }
```

Potential positive side-effect: less data to carry between stages, reduced memory footprint, improved performance (see, e.g., [this paper](#)).

LOOP TILING

Original:

```
for (i=0; i<m; i++)
  for (j=0; j<n; j++)
    ...=...*b[j];
```

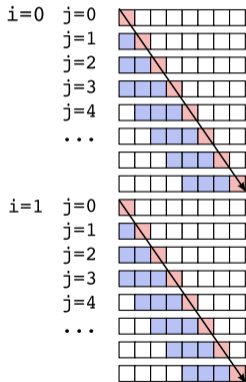

- - cached, LRU eviction policy
- - cache miss (read from memory, slow)
- - cache hit (read from cache, fast)

Cache size: 4

TILE=4

(must be tuned to cache size)

Cache hit rate without tiling: 0%

Cache hit rate with tiling: 50%

Tiled:

```
for (jj=0; jj<n; jj+=TILE)
  for (i=0; i<m; i++)
    for (j=jj; j<jj+TILE; j++)
      ...=...*b[j];
```

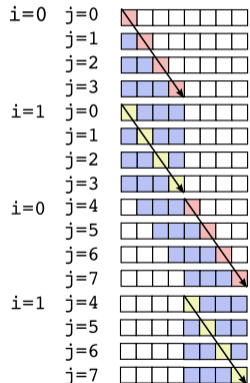

LOOP TILING (CACHE BLOCKING) -- PROCEDURE

```
1  for (int i = 0; i < m; i++) // Original code:  
2      for (int j = 0; j < n; j++)  
3          compute(a[i], b[j]); // Memory access is unit-stride in j
```

```
1  // Step 1: strip-mine inner loop  
2  for (int i = 0; i < m; i++)  
3      for (int jj = 0; jj < n; jj += TILE)  
4          for (int j = jj; j < jj + TILE; j++)  
5              compute(a[i], b[j]); // Same order of operation as original
```

```
1  // Step 2: permute  
2  for (int jj = 0; jj < n; jj += TILE)  
3      for (int i = 0; i < m; i++)  
4          for (int j = jj; j < jj + TILE; j++)  
5              compute(a[i], b[j]); // Re-use to j=jj sooner
```

EXAMPLE: MATRIX-VECTOR MULTIPLICATION

$$c_i = \sum_{j=0}^n A_{ij} b_j, \quad i = 0, 1, \dots, (m-1). \quad (2)$$

```

1 void Multiply(const double* const A, const double* const b,
2              double* const c, const long n, const long m){
3     assert(n%64 == 0);
4     #pragma omp parallel for
5     for (long i = 0; i < m; i++)
6     #pragma vector aligned
7         for (long j = 0; j < n; j++) // Each value of A[i*n+j] is used only once
8             c[i] += A[i*n+j] * b[j]; // Each value of b[j] is used a total of m times
9 }

```

Non-optimal performance due to inefficient cache use

APPLYING TILING

```
1  const long jTile = 4096L; assert(n%jTile == 0);
2  #pragma omp parallel
3  {
4      double temp_c[m] __attribute__((aligned(64)));
5      temp_c[:] =0;
6      #pragma omp for
7          for (long jj =0; jj < n; jj+=jTile) // Loop Tiling in j
8              for (long i = 0; i < m; i++)
9                  #pragma vector aligned
10                     for (long j =jj; j < jj+jTile; j++)
11                         temp_c[i] += A[i*n+j] * b[j];
12
13     for(long i = 0; i < m; i++) { // Reduction
14         #pragma omp atomic
15             c[i]+= temp_c[i];
16     } } }
```

CACHE BLOCKING + STRIP-MINE AND COLLAPSE

```
1  const long iTile = 64L;   assert(m%iTile == 0);
2  const long jTile = 4096L; assert(n%jTile == 0);
3  #pragma omp parallel
4  {
5      double temp_c[m] __attribute__((aligned(64))); temp_c[:] =0;
6  #pragma omp for collapse(2)
7      for (long ii = 0; ii < m; ii += iTile)
8          for (long jj = 0; jj < n; jj += jTile)
9              for (long i = ii; i < ii+iTile; i++)
10 #pragma vector aligned
11                 for (long j =jj; j < jj+jTile; j++)
12                     temp_c[i] += A[i*n+j] * b[j];
13
14     for(long i = 0; i < m; i++) {
15 #pragma omp atomic
16         c[i]+= temp_c[i];
17 } } }
```



EXAMPLE: MATRIX-VECTOR MULTIPLICATION

```

1 void RecursMultiply(const double* const A, const double* const b,
2     double* const c, const long n, const long m, const long lda){
3     const long jThreshold = 8192L; assert(n%jThreshold == 0);
4     const long iThreshold = 64L;  assert(m%iThreshold == 0);
5     if ((m<=iThreshold) && (n<=jThreshold)) { // Recursion threshold
6         // .... Base Case: Compute the result inside the tile ... //
7     } else { // Recursive divide-and-conquer
8         if (m*jThreshold > n*iThreshold) { // Split i-wise
9             double c1[m/2] __attribute__((aligned(64)));
10 #pragma omp task
11     { RecursMultiply(&A[0*lda + 0], &b[0], c1, n, m/2, lda); }
12     double c2[m/2] __attribute__((aligned(64)));
13     RecursMultiply(&A[(m/2)*lda + 0], &b[m/2], c2, n, m/2, lda);
14 #pragma omp taskwait
15     c[0:m/2] += c1[0:m/2]; c[m/2:m/2] += c2[0:m/2]; // Reduction
16     } else { // .... Split j-wise .... // }
17 } }

```

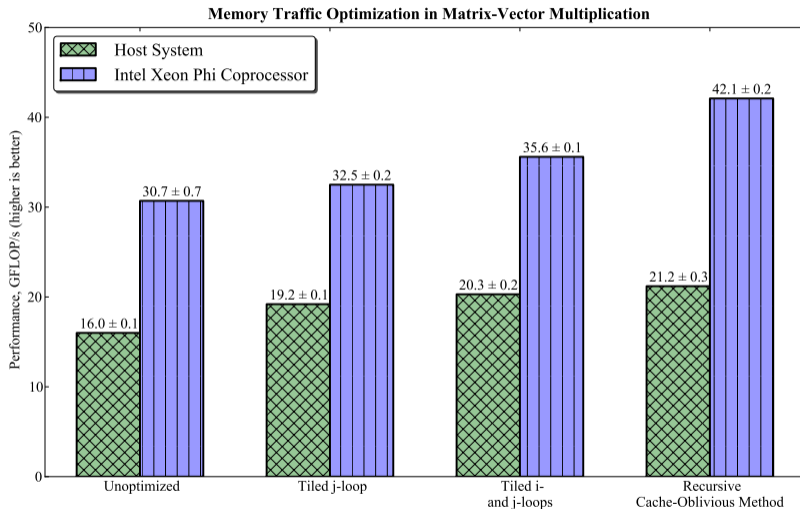
PERFORMANCE OF MATRIX VECTOR MULTIPLICATION





OPTIMIZING COMMUNICATION

PARALLEL PROGRAMMING FRAMEWORKS

Data-Parallel :

intrinsic, vector classes, automatic vectorization, array notation, kernels

Shared Memory :

Pthreads, Threading Building Blocks, OpenMP

Message Passing :

TCP/IP, MPI

STRUCTURE OF MPI APPLICATIONS: HELLO WORLD

```
1 #include "mpi.h"
2 #include <stdio>
3 int main (int argc, char *argv[]) {
4     MPI_Init (&argc, &argv); // Initialize MPI environment
5     int rank, size, namelen;
6     char name[MPI_MAX_PROCESSOR_NAME];
7     MPI_Comm_rank (MPI_COMM_WORLD, &rank); // ID of current process
8     MPI_Get_processor_name (name, &namelen); // Hostname of node
9     MPI_Comm_size (MPI_COMM_WORLD, &size); // Number of processes
10    printf ("Hello World from rank %d running on %s!\n", rank, name);
11    if (rank == 0) printf("MPI World size = %d processes\n", size);
12    MPI_Finalize (); // Terminate MPI environment
13 }
```

MPICH site contains a list of **MPI 3.2 routines**

COMPILING AND RUNNING MPI APPLICATIONS ON LOCALHOST

Compilation:

```
u100@c005% mpiicpc -o HelloMPI HelloMPI.cc
```

Command file mympi:

```
#PBS -l nodes=1  
cd $PBS_O_WORKDIR  
mpirun -host localhost -np 2 ./HelloMPI
```

Results:

```
u100@c005% qsub mympi  
2000  
u100@c005% cat mympi.o2000  
Hello World from rank 1 running on c005-n001!  
Hello World from rank 0 running on c005-n001!  
MPI World size = 2
```

MPI APPLICATIONS: MACHINE FILE

Machine files are especially useful when working on large clusters.

Machine file `hosts.txt`:

```
c005-n001:1  
c005-n002:1
```

Job submission:

```
vega@lyra% mpirun -machinefile hosts.txt ~/hello_mpi
```

Torque job file (assumes same executable path):

```
#PBS -l nodes=4  
cd $PBS_O_WORKDIR  
mpirun -machinefile $PBS_NODEFILE ./hello_mpi
```



COMMUNICATION PATTERNS

POINT TO POINT COMMUNICATION

```
1  if (rank == sender) {
2
3     char outgoingMsg[messageLength];
4     strcpy(outgoingMsg, "Hi There!");
5     MPI_Send(&outgoingMsg, messageLength, MPI_CHAR, receiver, tag, MPI_COMM_WORLD);
6
7
8  } else if (rank == receiver) {
9
10    char incomingMsg[messageLength];
11    MPI_Recv (&incomingMsg, messageLength, MPI_CHAR, sender,
12             tag, MPI_COMM_WORLD, &stat);
13    printf ("Received message with tag %d: '%s'\n", tag, incomingMsg);
14
15
16 }
```

COLLECTIVE COMMUNICATION: BROADCAST

```
1 int MPI_Bcast( void *buffer, int count, MPI_Datatype datatype,  
2 int root, MPI_Comm comm );
```

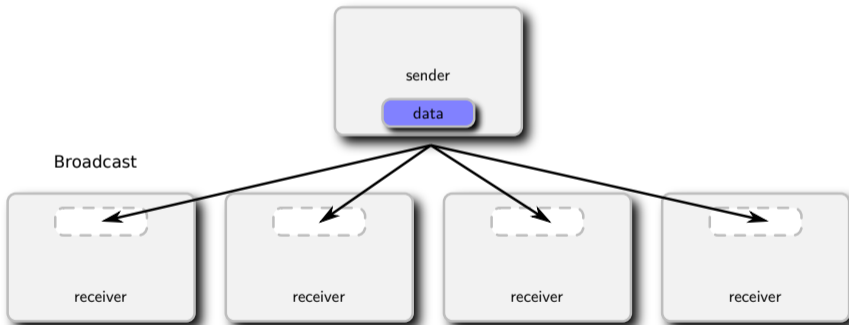

COLLECTIVE COMMUNICATION: SCATTER

```
1 int MPI_Scatter(void *sendbuf, int sendcnt, MPI_Datatype sendtype, void *recvbuf,  
2 int recvcnt, MPI_Datatype recvttype, int root, MPI_Comm comm);
```

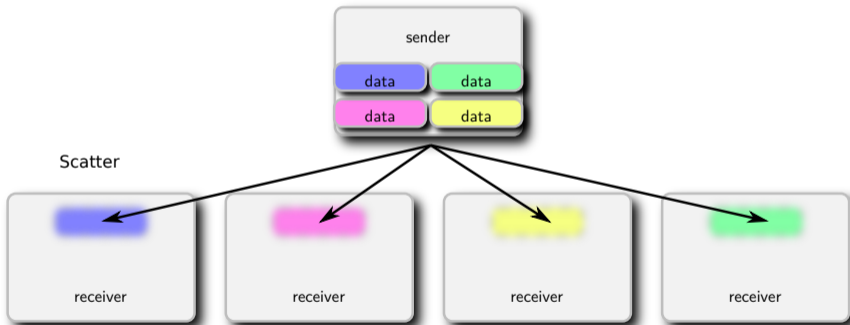

COLLECTIVE COMMUNICATION: GATHER

```
1 int MPI_Gather(void *sendbuf, int sendcnt, MPI_Datatype sendtype,  
2 void *recvbuf, int recvcnt, MPI_Datatype recvtype, int root, MPI_Comm comm);
```

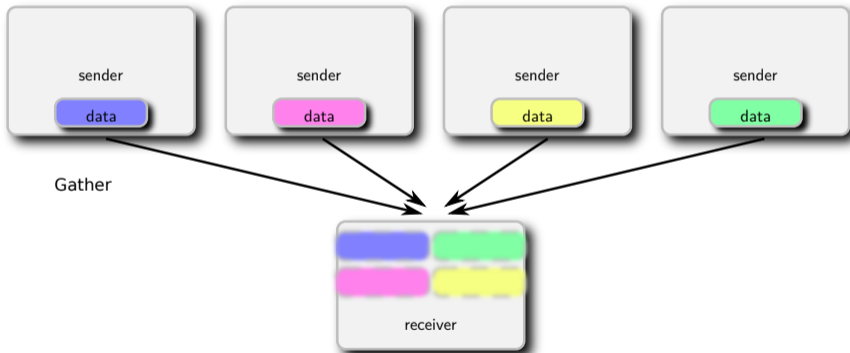

COLLECTIVE COMMUNICATION: REDUCTION

```
1 int MPI_Reduce(void *sendbuf, void *recvbuf, int count, MPI_Datatype datatype,  
2 MPI_Op op, int root, MPI_Comm comm);
```

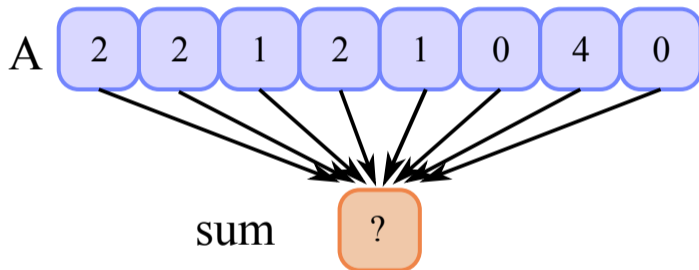

Available reducers: max/min, minloc/maxloc, sum, product, AND, OR, XOR (logical or bitwise).



INTER-OPERATION WITH OPENMP

HYBRID MPI+OPENMP

Using OpenMP inside of MPI processes:

- ▶ Reduces the memory footprint
- ▶ Decreases the number of MPI ranks, which reduces communication
- ▶ May incur thread synchronization overhead
- ▶ Optimal number of threads in MPI processes must be established empirically

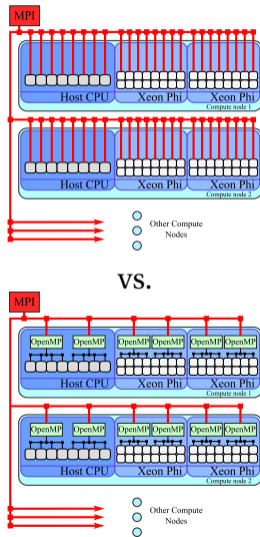

- ▶ MPI pins processes to cores and sets OpenMP affinity for them.
- ▶ To tune pinning: `I_MPI_PIN, I_MPI_PIN_DOMAIN`
- ▶ To diagnose process pinning: `I_MPI_DEBUG=4`
- ▶ For MPI calls from multiple OpenMP threads, use `-mt_mpi`
- ▶ More information in the [MPI Reference Manual](#)

MULTI-THREADING WITHIN MPI PROCESSES

```

1  if(myRank == 0) { // Rank 0 has both a boss and a worker inside:
2      const int nThreads = omp_get_max_threads();  omp_set_nested(1);
3      #pragma omp parallel sections num_threads(2)
4          {
5      #pragma omp section
6          { DistributeWork(nOptions, option, mpiWorldSize); } // Boss
7      #pragma omp section
8          { omp_set_num_threads(nThreads-1); // Worker in rank 0:
9            ReceiveWork(option, payoff, myRank, optioncount); } // ...

```

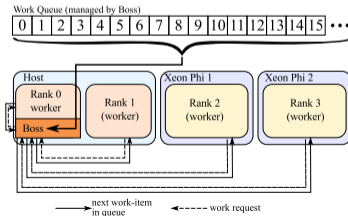

EXAMPLE OF OPENMP AND MPI INTER-OPERATION

Number of threads per process may be a tuning parameter:

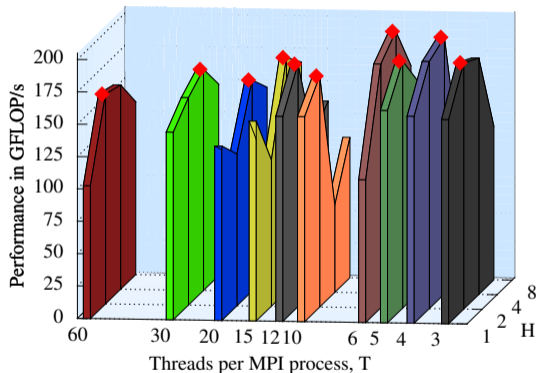
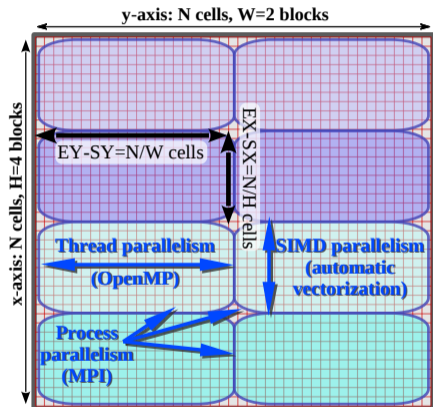

Case study: [this paper](#)

EXAMPLE: ASIAN OPTIONS, HETEROGENEOUS DISTRIBUTED COMPUTING

EXAMPLE: THE MONTE CARLO METHOD OF ASIAN OPTION PRICING

1) Simulate Random-Walk of Asset Price

$$dS(t) = \mu S(t)dt + \sigma S(t)dB(t)$$

Using the Solution

$$S(t) = S(0)e^{(\mu - \frac{1}{2}\sigma^2)t + \sigma\sqrt{t}N(0,1)}$$

2) Perform Asian Option Price Averaging

$$\langle S \rangle_{\text{arithm}} = \frac{1}{N} \sum_{i=0}^{N-1} S(t_i),$$

$$\langle S \rangle_{\text{geom}} = \exp \left(\frac{1}{N} \sum_{i=0}^{N-1} \log S(t_i) \right)$$

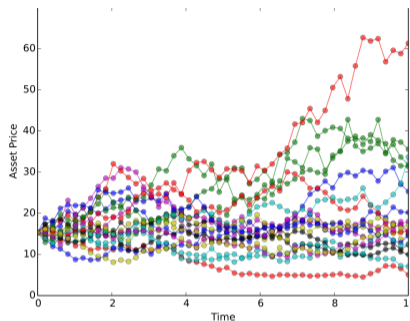

3) Compute Discounted Pay-off

$$P_{\text{put}} = e^{-rT} \mathbb{E} (\max \{0; K - \langle S \rangle\}),$$

$$P_{\text{call}} = e^{-rT} \mathbb{E} (\max \{0; \langle S \rangle - K\})$$

More information: [this paper](#)

HETEROGENEOUS CALCULATION WITHOUT LOAD BALANCING

```

1  const double optionsPerProcess = double(nOptions)/double(mpiWorldSize);
2  const int myFirstOption = int(optionsPerProcess*(myRank));
3  const int myLastOption = int(optionsPerProcess*(myRank+1));
4
5  // Static, even load distribution: assign options to ranks
6  for (int i = myFirstOption; i < myLastOption; i++)
7      ComputeOptionPayoffs(option[i], payoff[i]);

```

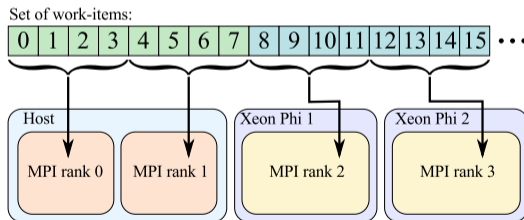

STATIC LOAD BALANCING

```

1  if (rankTypes[myRank] == 0) { // I am a MIC-based rank
2      double optionsPerProc = double(lastOptForCPUs)/double(cpuRanks.size());
3      myFirstOpt = int(optionsPerProc*(myGroupRank));
4      myLastOpt = int(optionsPerProc*(myGroupRank+1.0));
5  } else { // I am a CPU-based rank
6      double optionsPerProc = double(nOpts-lastOptForCPUs)/double(micRanks.size());
7      myFirstOpt=lastOptForCPUs+int(optionsPerProc*(myGroupRank));
8      myLastOpt=lastOptForCPUs+int(optionsPerProc*(myGroupRank+1.0)); }

```

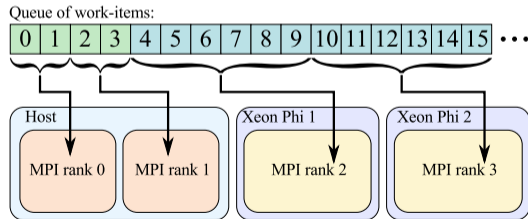

STATIC LOAD BALANCING: PARAMETER TUNING

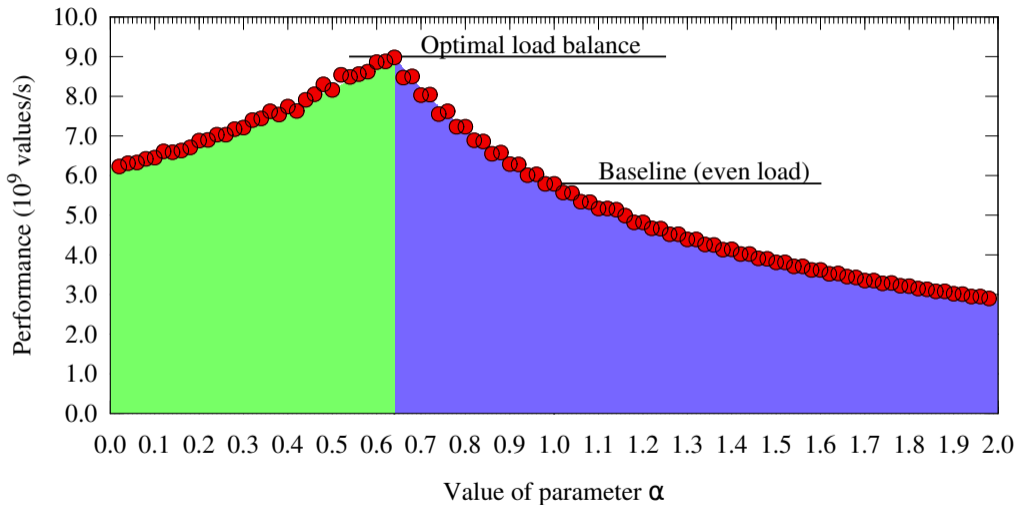

DYNAMIC LOAD BALANCING

```

1  if (myRank == 0) // Boss's branch
2      DistributeWork(nOptions, option, mpiWorldSize);
3  else // Workers' branch
4      ReceiveWork(option, payoff, myRank);

```

Work Queue (managed by Boss)

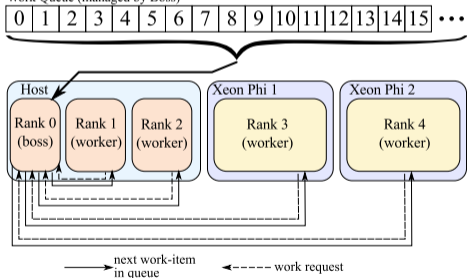

or

Work Queue (managed by Boss)

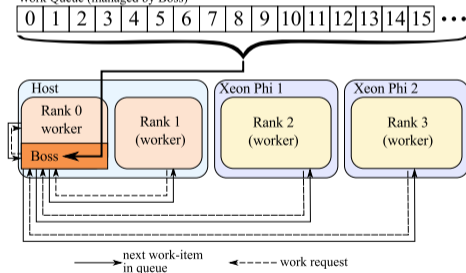

PERFORMANCE WITH DIFFERENT SCHEDULING MODES

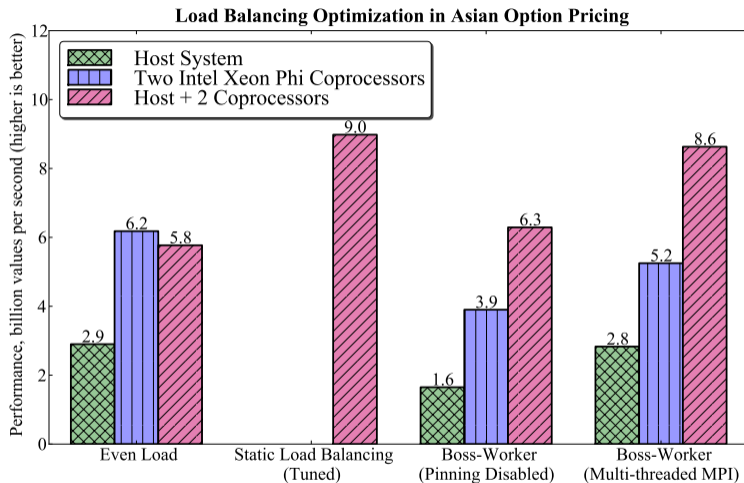

Refer to the book for explanation on the last two results.



WHERE TO LEARN MORE



THE "HOW" SERIES TRAINING

DEEP DIVE

WITH CODE MODERNIZATION EXPERTS

It's free

→ [HOWSERIES.COM](https://howseries.com)

*10x 2-hour sessions | 24-hour 2-weeks remote access to a system

ISBN: 978-0-9885234-0-1 (508 pages, Electronic or Print)

Parallel Programming
and Optimization with
Intel® Xeon Phi™
Coproprocessors

Handbook on the Development and
Optimization of Parallel Applications
for Intel® Xeon® Processors
and Intel® Xeon Phi™ Coprocessors

© Colfax International, 2015

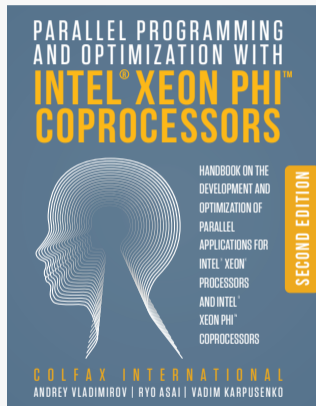

<http://xeonphi.com/book>

COLFAX RESEARCH

Log In/Out or Register

READ WATCH LEARN CONNECT JOIN

To search, type and hit enter

Popular

The Hands-On Tutorials (HOT) webinars: details on efficient programming for Intel architecture

The Hands-On Workshop (HOW) Series

Introduction to Intel DAAL, Part 1: Polynomial Regression with Batch Mode Computation

Parallel Programming Book

Introduction to parallel programming, deep discussion of optimization techniques, exercises.

© 2015, Colfax International, 508 pages.

Research and Educational Publications

Introduction to Intel DAAL, Part 1: Polynomial Regression with Batch Mode Computation

Optimization Techniques for the Intel MIC Architecture, Part 3 of 3: False Sharing and Padding

Software Developer's Introduction to the HGST Ultrastar Archive H800 SMR Drives

Optimization Techniques for the Intel MIC Architecture, Part 2 of 3: Strip-Mining for Vectorization

Optimization Techniques for the Intel MIC Architecture, Part 1 of 3: Multi-Threading and Parallel Reduction

Performance to Power and Performance to Cost Ratios with Intel Xeon Phi Coprocessors (and why ix Acceleration May Be Enough)

Featured Video

See Research material on vectorization in a streaming mode

▶

[View Additional Reading](#)

Consulting

Twitter Facebook LinkedIn Share

Colfax offers consulting services for enterprises, research help you to:

- Optimize your existing application to take advantage of parallelism, from vectors to cores to clusters and
- Future-proof your application for upcoming innovations
- Accelerate your application using coprocessor tech
- Investigate the potential system configurations that satisfy your cost, power, performance requirements.
- Take a clean slate to develop a novel architecture to realize your computing pro

Episode 2.1 — Purpose of the MIC architecture

▶

Software Developer's Introduction to the HGST Ultrastar Archive H800 SMR Drives

Introduction by Intel and HGST

Colfax offers consulting services for enterprises, research help you to:

- Optimize your existing application to take advantage of parallelism, from vectors to cores to clusters and
- Future-proof your application for upcoming innovations
- Accelerate your application using coprocessor tech
- Investigate the potential system configurations that satisfy your cost, power, performance requirements.
- Take a clean slate to develop a novel architecture to realize your computing pro

Fluid Dynamics with Fortran on Intel Xeon Phi coprocessors

Introduction by Intel and Fortran

Colfax offers consulting services for enterprises, research help you to:

- Optimize your existing application to take advantage of parallelism, from vectors to cores to clusters and
- Future-proof your application for upcoming innovations
- Accelerate your application using coprocessor tech
- Investigate the potential system configurations that satisfy your cost, power, performance requirements.
- Take a clean slate to develop a novel architecture to realize your computing pro

Configuration and Benchmarks of Peer-to-Peer Communication over Gigabit Ethernet and InfiniBand in a Cluster with Intel Xeon Phi Coprocessors

Introduction by Intel and Fortran

Colfax offers consulting services for enterprises, research help you to:

- Optimize your existing application to take advantage of parallelism, from vectors to cores to clusters and
- Future-proof your application for upcoming innovations
- Accelerate your application using coprocessor tech
- Investigate the potential system configurations that satisfy your cost, power, performance requirements.
- Take a clean slate to develop a novel architecture to realize your computing pro

Interview with James Reinders: future of Intel MIC architecture, parallel programming, education

Introduction by Intel and Fortran

Colfax offers consulting services for enterprises, research help you to:

- Optimize your existing application to take advantage of parallelism, from vectors to cores to clusters and
- Future-proof your application for upcoming innovations
- Accelerate your application using coprocessor tech
- Investigate the potential system configurations that satisfy your cost, power, performance requirements.
- Take a clean slate to develop a novel architecture to realize your computing pro

http://colfaxresearch.com/

colfaxresearch.com/events

WHERE TO LEARN MORE

© Colfax International, 2013–2017

INTEL RESOURCES

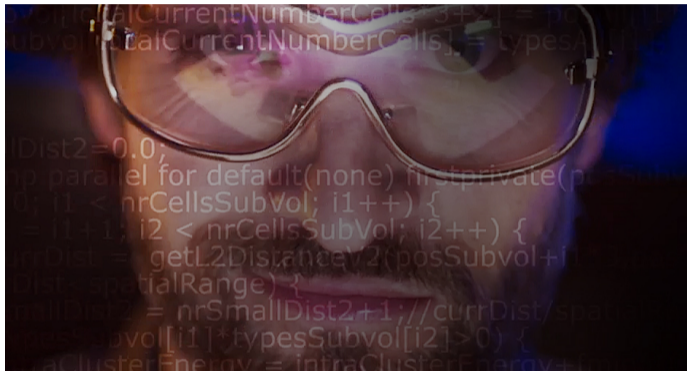

software.intel.com/modern-code



intel.com/xeonphi

§4. PREPARING FOR INTEL XEON PHI PROCESSORS

INTEL XEON PHI PROCESSORS (2ND GEN)

- ▶ Specialized for floating-point computing
- ▶ Highly-parallel (72 cores*)
- ▶ Balanced for compute
- ▶ Less forgiving than Xeon
- ▶ Theor. ~ 3.0 TFLOP/s in DP*
- ▶ Meas. ~ 490 GB/s bandwidth*

* Intel Xeon Phi processor, Knights Landing architecture (2016), top-of-the-line (e.g., 7290P)

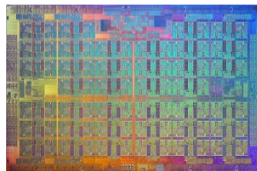
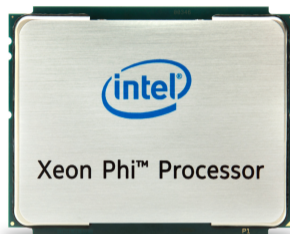

KNL DIE ORGANIZATION

- ▶ Mesh interconnect relaxes data locality requirement [somewhat]
- ▶ All-to-all, quadrant or sub-numa domain communication in mesh

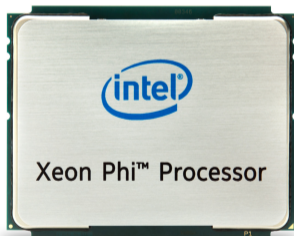

≤ 16 GiB on-package MCDRAM, ~ 400 GB/s

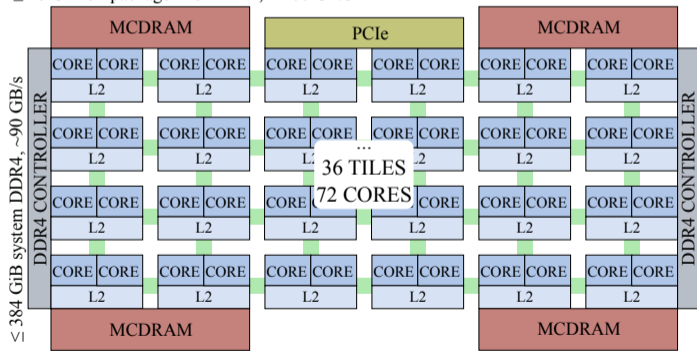

KNL CORES

- ▶ Even more power in vector units
- ▶ Binary compatible with Xeon, but in legacy mode

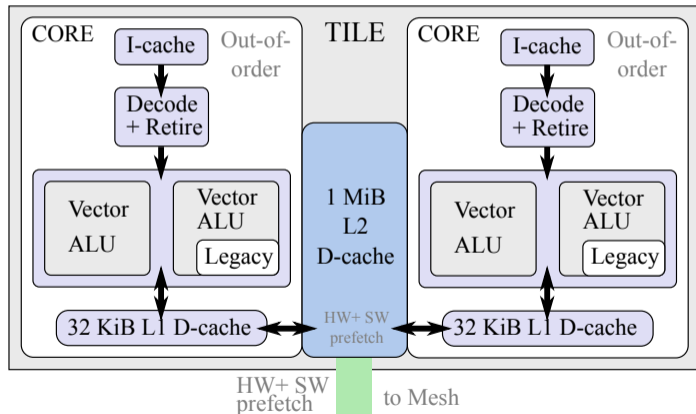
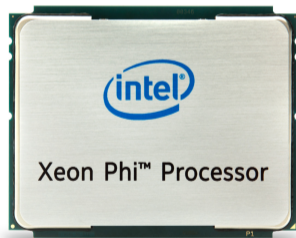

GET READY FOR INTEL® XEON PHI PROCESSORS (CODENAMED: KNIGHTS LANDING)



GET READY FOR KNL*

3

papers

AVX-512 | CLUSTERING MODES | MCDRAM

* Colfax series of webinars, training and white papers

colfaxresearch.com/knl-ready



HOW SERIES "KNIGHTS LANDING":

PROGRAMMING AND OPTIMIZATION FOR
INTEL XEON PHI X200 FAMILY

Free 2-hour video course

colfaxresearch.com/how-knl



COMPILING WITH AVX-512

AVX-512 FEATURES

- ▶ AVX-512F (Fundamentals)
 - Extension of most AVX2 instructions to 512-bit vector registers.
- ▶ AVX-512CD (Conflict Detection)
 - Efficient conflict detection (application: binning).
- ▶ AVX-512ER (Exponential and Reciprocal)
 - Transcendental function (exp, rcp and rsqrt) support.
- ▶ AVX-512PF (Prefetch)
 - Prefetch for scatter and gather.

Learn more: colfaxresearch.com/knl-avx512

INTEL COMPILER SUPPORT FOR AVX-512

Intel C, C++ and Fortran compilers \geq 15.0 support AVX-512

```
user@knl% icc -v
icc version 16.0.1 (gcc version 4.8.5 compatibility)
user@knl% icc -help
// ... truncated output ... //
-x<code>
    ...
    MIC-AVX512
    CORE-AVX512
    COMMON-AVX512
```

- ▶ -xMIC-AVX512 : for KNL (supports F, CD, ER, PF)
- ▶ -xCORE-AVX512 : for future Xeon (supports F, CD, DQ, BW, VL)
- ▶ -xCOMMON-AVX512 : common to KNL and Xeon (supports F, CD)

GCC SUPPORT FOR AVX-512

GCC \geq 4.9.1 supports AVX-512 instruction set.

```
1 for(int i = 0; i < n; i++)  
2   B[i] = A[i] + B[i];
```

Basic automatic vectorization support: add -m flags and -O3:

```
user@knl% g++ -v  
gcc version 4.9.2 (GCC)  
user@knl% g++ foo.cc -mavx512f -mavx512er -mavx512cd -mavx512pf -O3
```

Get assembly:

```
user@knl% g++ -s foo.cc -mavx512f -O3  
user@knl% cat foo.s  
...  
vmovapd -16432(%rbp,%rax), %zmm0  
vaddpd -8240(%rbp,%rax), %zmm0, %zmm0  
vmovapd %zmm0, -8240(%rbp,%rax)
```

PERFORMANCE CONSIDERATIONS

Even if your code is vectorized, tuning may unlock more performance.

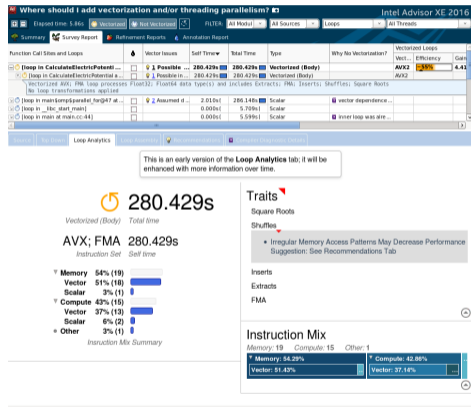

download paper to learn more

- ▶ Providing enough parallelism.
 - More consecutive vector operations required to overcome vectorization latency.
- ▶ Loop pipelining and unrolling.
 - Double the pipeline stages to populate.
- ▶ Better vectorization patterns.
 - Avoid long latency operations with unit-stride and unmasked operations.



USING HIGH-BANDWIDTH MEMORY

MODES OF HBM OPERATION

Flat Mode

- ▶ MCDRAM treated as a NUMA node
- ▶ Users control what goes to MCDRAM

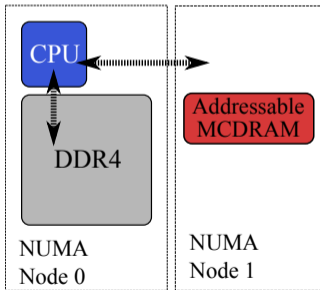

Cache Mode

- ▶ MCDRAM treated as a Last Level Cache (LLC)
- ▶ MCDRAM is used automatically

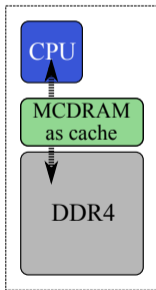

Hybrid Mode

- ▶ Combination of Flat and Cache
- ▶ Ratio can be chosen in the BIOS

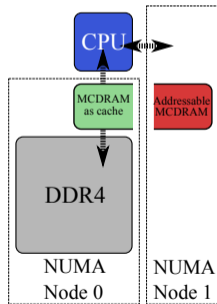

FLOW CHART FOR BANDWIDTH-BOUND APPLICATIONS

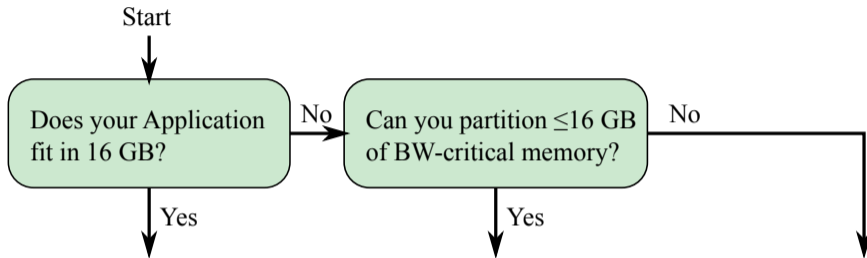

numactl	Memkind	Cache mode
<ul style="list-style-type: none"> ▶ Run the whole program in HBM ▶ No code modification 	<ul style="list-style-type: none"> ▶ Selectively allocate data to HBM ▶ Add memkind calls 	<ul style="list-style-type: none"> ▶ Allow the chip to figure out how to use HBM ▶ No code modification

RUNNING APPLICATIONS IN HBM WITH NUMACTL

- ▶ Finding information about the NUMA nodes in the system.

```
user@knl% # In Flat mode of MCDRAM
user@knl% numactl -H
available: 2 nodes (0-1)
node 0 cpus: 0 1 2 3 4 5 6 7 8 9 10 11 12 13 14 15 16 17 18 19 20 ... 254 255
node 0 size: 98207 MB
node 0 free: 94798 MB
node 1 cpus:
node 1 size: 16384 MB
node 1 free: 15991 MB
```

- ▶ Binding the application to HBM (Flat/Hybrid)

```
user@knl% gcc myapp.c -o runme -mavx512f -O2
user@knl% numactl --membind 1 ./runme
// ... Application running in HBM ... //
```

ALLOCATION IN HBM WITH MEMKIND LIBRARY

Manual allocation to HBM possible with hbwmalloc and Memkind Library.

```
1 #include <hbwmalloc.h>
2
3 // Basic allocation in HBM
4 double* A = (double*) hbw_malloc(sizeof(double)*n);
5
6 // Allocation with alignment
7 double* B;
8 int ret = hbw_posix_memalign((void**) &B, 64, sizeof(double)*n);
9
10 hbw_free(A); hbw_free(b); // Special deallocator
```

In Fortran:

```
1 REAL, ALLOCATABLE :: A(:)
2 !DEC$ ATTRIBUTES FASTMEM :: A
3 ALLOCATE (A(1:N))
```

COMPILATION WITH MEMKIND LIBRARY AND HBWMALLOC

To compile C/C++ applications:

```
user@knl% icpc -lmemkind foo.cc -o runme
user@knl% g++ -lmemkind foo.cc -o runme
```

To compile Fortran applications:

```
user@knl% ifort -lmemkind foo.f90 -o runme
user@knl% gfortran -lmemkind foo.f90 -o runme
```

Open source distribution of Memkind library can be found at:

memkind.github.io/memkind

Learn more:

colfaxresearch.com/knl-mcdram

STREAM BENCHMARK

- ▶ Industry-standard tool for memory bandwidth measurement
- ▶ 4 tests: COPY, ADD, SCALE and TRIAD
- ▶ Download from Dr. John McCalpin's site:
www.cs.virginia.edu/stream/

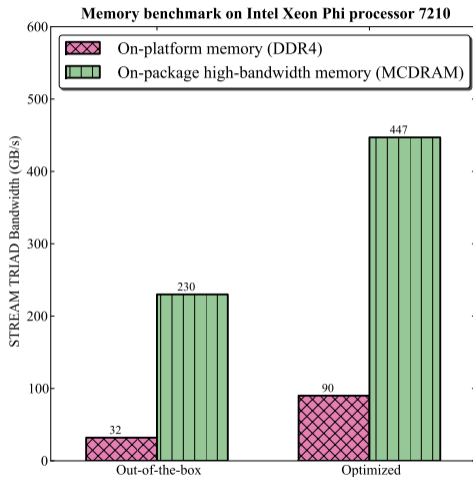



LEVERAGING CLUSTERING MODES

CLUSTERING MODES: QUADRANT/HEMISPHERE

Tag Directory (TD) and memory reside in the same quadrant.

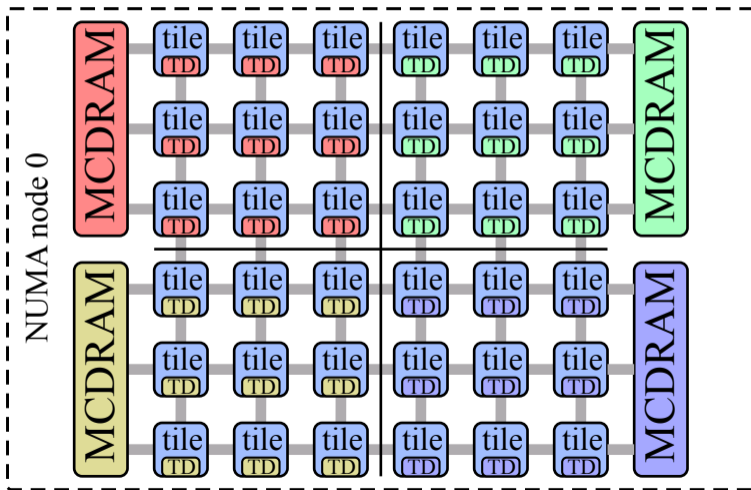

CLUSTERING MODES: SNC-4/SNC-2

Cores appear as 4 (or 2) NUMA nodes.

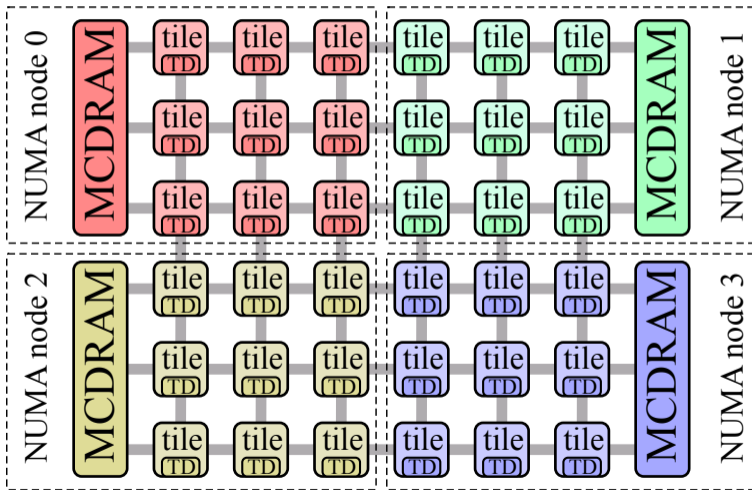

HOW TO USE CLUSTERING MODES

Nested OpenMP

```

1  #pragma omp parallel
2  {
3      // ...
4      #pragma omp parallel
5      {
6          // ...
7      }
8  }
```

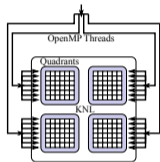

```

user@kn1% OMP_NUM_THREADS=4,72
user@kn1% OMP_NESTED=1
```

MPI+OpenMP

```

1  stat = MPI_Init();
2  // ...
3  #pragma omp parallel
4  {
5      // ...
6  }
7  // ...
8  MPI_Finalize();
```

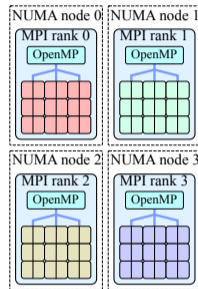

```

user@kn1% mpirun -host kn1 \
> -np 4 ./myparallel_app
```

Learn more: colfaxresearch.com/knl-numa



§5. INTEL LIBRARIES



INTEL MKL: THE MAGIC PILL

Intel[®] Math Kernel Library (MKL) — free standard mathematical functions optimized for Intel architecture.

Dense Linear Algebra

BLAS + PBLAS
LAPACK + ScaLAPACK
Extended eigensolver

Fourier Transform

Multi-threaded
Cluster mode
1D and multi-dimensional

Statistics and Probability

Random number generators
Convolution and correlation
Summary statistics

Sparse Linear Algebra

SpBLAS
Iterative, direct solvers
Preconditioners

Numerical Analysis

Partial differential equations
Nonlinear optimization
Data fitting. Vector math.

Machine Learning

New

DNN Primitives:
Convolution. Inner product.
ReLU, LRNC, etc.

MKL C/C++ CODE SAMPLES

Thread-safe, vectorized RNG.

```
1 float *matrix = (float *) malloc(sizeof(float)*N*M);
2 #pragma omp parallel
3 { VSLStreamStatePtr rnStream;
4   vslNewStream( &rnStream, VSL_BRNG_MT19937, random_seed);
5 #pragma omp for
6   for(size_t i = 0; i < N; i++)
7     vsRngUniform(VSL_RNG_METHOD_UNIFORM_STD, rnStream, M, matrix, -1.0, 1.0);
8 }
```

Optimized BLAS API.

```
1 float A[N*N], B[N*N], C[N*N];
2 cblas_dgemm(CblasRowMajor, CblasNoTrans, CblasNoTrans,
3            N, N, N, 1.0, A, N, B, N, 0.0, C, N);
```

For more, see the [MKL documentation](#)

MKL WITH R

Install R with MKL support.

```
user@host% ./configure --with-blas="-L/opt/intel/mkl/lib/intel64 \
% -lmkl_intel_lp64 -lmkl_core -lmkl_intel_thread -lpthread -lm" \
% --with-lapack CC=icc CFLAGS="-O2 -qopenmp -I/opt/intel/mkl/include" \
% CXX=icpc CXXFLAGS="-O2 -qopenmp -I/opt/intel/mkl/include" F77=ifort \
% FFLAGS="-O2 -qopenmp -I/opt/intel/mkl/include" FC=ifort FCFLAGS="-O2 \
% -qopenmp -I/opt/intel/mkl/include" --prefix=/opt/R-3.4.0
user@host% make && make install
```

In-place upgrade: no code change required.

```
user@host% cat gemm.R
N=5000
A<-matrix(runif(N*N), N, N)
B<-matrix(runif(N*N), N, N)
C = tcrossprod(A, B)
```

MKL_VERBOSE

Use MKL_VERBOSE to see the calls to MKL and overhead of the calls.

```
user@host% cat gemm.R
N=5000
A<-matrix(runif(N*N), N, N)
B<-matrix(runif(N*N), N, N)
for(i in 1:10) {
  Sys.time()->start
  C = tcrossprod(A, B)
  print(Sys.time()-start)
}
user@host% export MKL_VERBOSE=1
user@host% Rscript gemm.R
// ... //
MKL_VERBOSE DGEMM(N,T,5000,5000,5000,0x7fffc4b0fc60, ... ) 153.73ms ...
Time difference of 0.4924946 secs
MKL_VERBOSE DGEMM(N,T,5000,5000,5000,0x7fffc4b0fc60, ... ) 151.93ms ...
Time difference of 0.4966147 secs
```

MKL WITH VARIOUS LANGUAGES

MKL is supported on various languages. For example:

- ▶ C/C++ - linked to library [Intel MKL Developer Reference for C](#)
- ▶ R - compiled in [Intel article](#).
- ▶ Fortran -linked to library [Intel MKL Developer Reference for Fortran](#)
- ▶ Python - compiled in [Intel Distribution for Python](#)
- ▶ Julia - compiled in [git repo](#) (under section "Intel compilers and Math Kernel Library (MKL)")
- ▶ Matlab - compiled in [Intel article with instructions](#)

Intel MKL download can be found at <https://software.intel.com/en-us/mkl>.

ENVIRONMENT TUNING MAY BE NECESSARY

$2 \cdot 10^5$ FFTs of size 2048. See [HOW "KNL" for details](#).

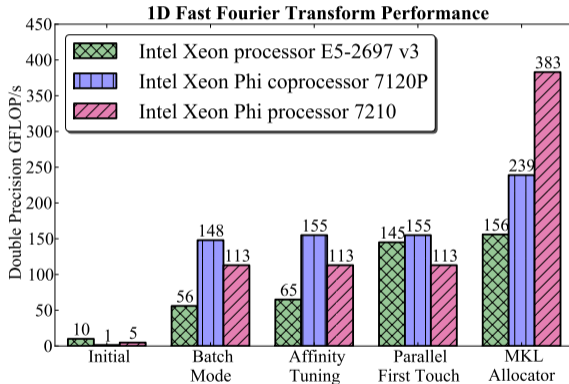



INTEL DAAL: DATA ANALYTICS

Analysis

- Low Order Moments
- Quantile
- Correlation and Variance
- Cosine Distance Matrix
- Correlation Distance Matrix
- K-Means Clustering
- Principal Component Analysis
- Cholesky Decomposition
- Singular Value Decomposition
- QR Decomposition
- Expectation-Maximization
- Multivariate Outlier Detection
- Univariate Outlier Detection
- Association Rules
- Kernel Functions
- Quality Metrics

Training & prediction

- Regression
 - Linear/Ridge Regression
- Classification
 - Naive Bayes Classifier
 - Boosting
 - SVM
 - Neural Networks
 - Multi-Class Classifier

Portal: [DAAL page](#). See also: [intro article](#), [CR papers](#).

DAAL C++ CODE SAMPLE

```
1 using namespace daal;
2 using namespace daal::data_management;
3 using namespace daal::algorithms::linear_regression;
4 // Setting up the training sets.
5 services::SharedPtr<NumericTable> trnFeatures(trnFeatNumTable);
6 services::SharedPtr<NumericTable> trnResponse(trnRespNumTable);
7 // Setting up the algorithm object
8 training::Batch<> algorithm;
9 algorithm.input.set(training::data, trnFeatures);
10 algorithm.input.set(training::dependentVariables, trnResponse);
11 // Training
12 algorithm.compute();
13 // Extracting the result
14 services::SharedPtr<training::Result> trainingResult;
15 trainingResult = algorithm.getResult();
```

See [Colfax Research paper](#) for more.

SCIKIT-LEARN WITH DAAL

Parts of scikit-learn have been integrated with DAAL ([Intel video](#))

```
user@host% cat kmeans.py
from sklearn.cluster import KMeans
from sklearn.datasets import fetch_mldata
import time
data = fetch_mldata("MNIST original").data
start = time.time()
kmeans = KMeans(n_clusters=64).fit(data)
print(str(time.time()-start)+" seconds")
user@host% # default sklearn
user@host% /usr/local/python kmeans.py
1944.01453304 seconds      # 10 runs
user@host% # Intel DAAL enhanced sklearn
user@host% /opt/intel/intelpython_update_3/intelpython2/bin/python kmeans.py
5.6174788475 seconds     # 5 runs
```

Optimization of K-Means clustering: [Colfax Research Paper](#)

SCIKIT-LEARN PERFORMANCES

Python* Performance as a Percentage of C++ Intel® Data Analytics Acceleration Library
(Intel® DAAL) on Intel® Xeon® Processors (Higher is Better)

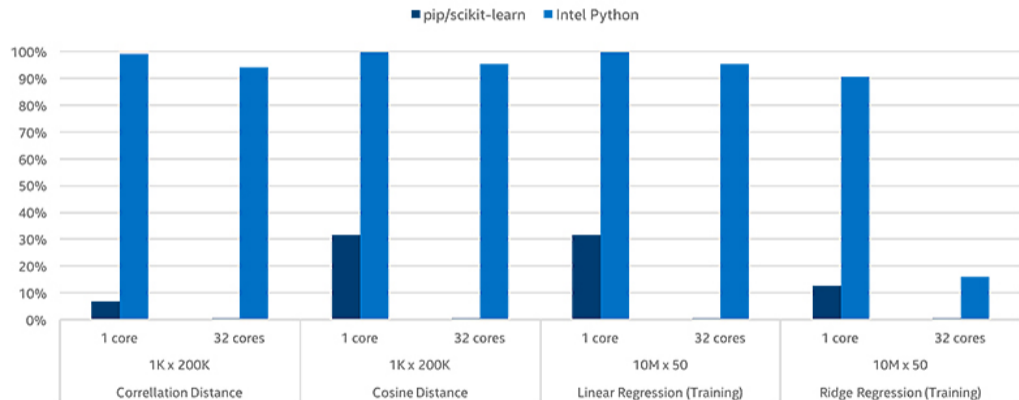

Source: [Intel DAAL features page](#)



§6. INTEL DISTRIBUTION FOR PYTHON

INTEL DISTRIBUTION FOR PYTHON

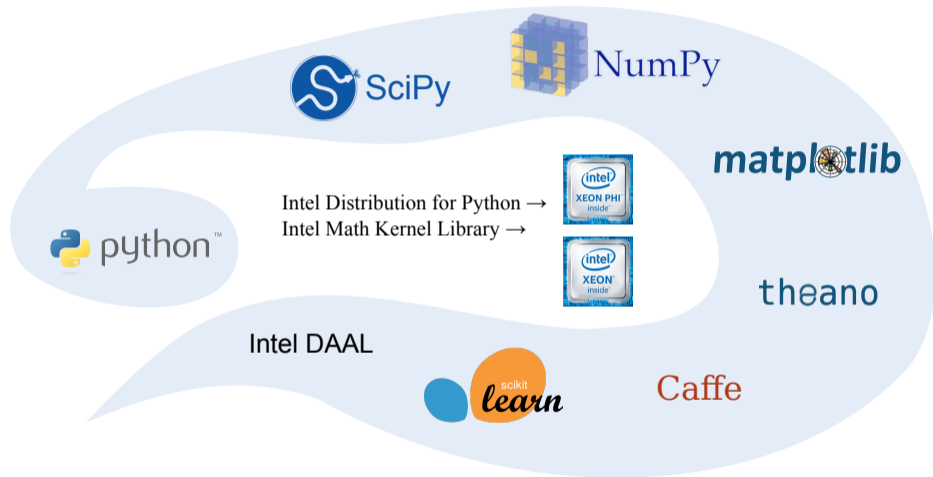

Portal: software.intel.com/intel-distribution-for-python. See also: [CR paper](#).

GETTING INTEL PYTHON

Intel Python can be downloaded from [Intel website](#)

```
user@host% tar xzf l_python2_pu3_2017.3.053.tgz
user@host% cd l_python2_pu3_2017.3.053
user@host% ./install.sh
// Follow on-screen instructions
user@host% export PATH=/opt/intel/intelpython27/bin:${PATH}
```

Also supported for Anaconda ([Intel article](#))

```
user@host% # Requires conda 4.1.11 and above
user@host% conda config --add channels intel # use intel as default
user@host% conda create -n idp intelpython2_core python=2 # core only
user@host% # conda create -n idp intelpython2_full python=2 # full install
user@host% source activate idp
```

DIMENSIONALITY REDUCTION

Dimensionality Reduction – reducing number of variables with minimal loss of information.

```
import numpy as np
from sklearn.datasets import fetch_mldata
from sklearn.decomposition import PCA
# getting data, and preprocessing
data = fetch_mldata("MNIST original").data[0:60000,:]/255
data = data - np.mean(data, axis=0)
# dimensionality reduction
print("Original data: "+str(transformed_data.shape))
pca = PCA(n_components=200).fit(data)
print(str(np.sum(pca.explained_variance_ratio_)*100)+"% of variance")
transformed_data = np.dot(data, np.transpose(pca.components_))
print("Transformed data: "+str(transformed_data.shape))
```

```
Original data: (60000, 784)
87.98% of variance
Transformed data: (60000, 200)
```

DIMENSIONALITY REDUCTION PERFORMANCE

```
t_pca_start = time.time()
pca = PCA(n_components=200).fit(data)
print("PCA :"+str(time.time()-t_pca_start)+" seconds")
# ... same for np.dot ...
```

```
user@host% numactl -m 1 python dimensionality-reduction.py
```

On Intel Xeon Phi processor 7250:

- ▶ System Python (numpy ver. 1.13.1, scikit-learn ver. 0.18.2)

```
PCA : 81.3773860931 seconds    Dot : 6.7592010498 seconds
```

- ▶ Intel Distribution for Python (2017 update 3)

```
PCA : 5.84652495384 seconds    Dot : 0.038341999054 seconds
```

*Similar performance for `fit_transform()`



HOW TO GET THE MOST OUT OF NUMPY AND SCIPY

INTEL PYTHON PERFORMANCE

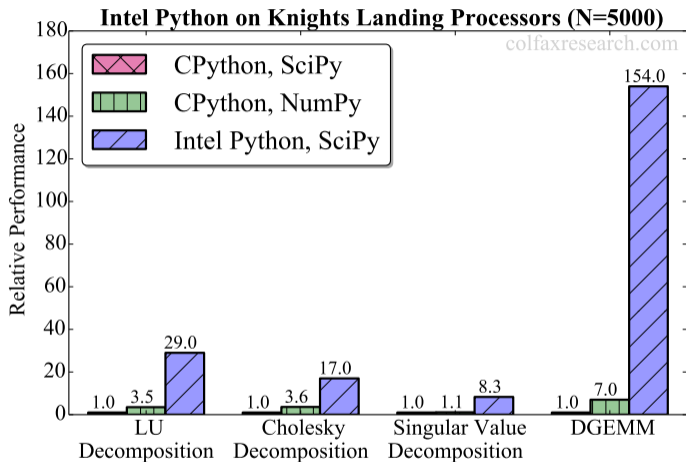

Portal: software.intel.com/intel-distribution-for-python. See also: [CR paper](#).

DGEMM WITH SCIPY

```
import numpy as np
from numpy.random import rand as rn
from scipy.linalg.blas import dgemm as dgemm

m=5000
n=5000
k=5000

// Using column-major format with order="F"
A = np.array(np.random.rand(m, n), dtype = np.double, order="F");
B = np.array(np.random.rand(n, k), dtype = np.double, order="F");

// Scipy matrix-matrix multiplication
C=dgemm(alpha=1.0, a=A, b=B, c=C, overwrite_c=1, trans_b=1)
```

DGEMM WITH NUMPY

```
import numpy as np
from numpy.random import rand as rn

m=5000
n=5000
k=5000

// Using row-major by default (you can also set order="C")
A = np.array(np.random.rand(m, n), dtype = np.double);
B = np.array(np.random.rand(n, k), dtype = np.double);

// Numpy matrix-matrix multiplication
C = np.dot(A, B)
```

MISC. SCIPY WORKLOADS

```
from scipy.linalg import lu as lu;
# ... #
A = np.array(np.random.rand(k, k), dtype = np.double, order='F')
P,L,U = lu(A, permute_l=False, overwrite_a=True, check_finite=False)
```

```
from scipy.linalg import cholesky as cholesky
# ... #
A = np.array(tempA, dtype=np.double, order='F')
L = cholesky(A, overwrite_a=True, check_finite=False)
```

```
from scipy.linalg import svd as svd
# ... #
A = np.array(np.random.rand(k, k), dtype = np.double, order='F');
U, s, V = svd(A)
```



§7. INTEL-OPTIMIZED DL FRAMEWORKS

INTEL MKL AND INTEL MKL-DNN

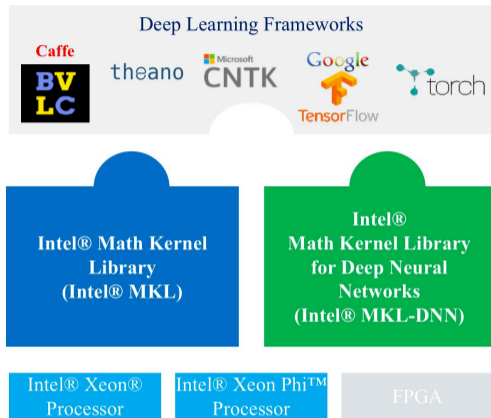

Intel® MKL	Intel® MKL-DNN
DNN primitives + wide variety of other math functions	DNN primitives
C DNN APIs (C++ future)	C/C++ DNN APIs
Binary distribution	Open source DNN code ¹
Free community license. Premium support available as part of Intel® Parallel Studio XE	Apache 2.0 license
Broad usage DNN primitives; not specific to individual frameworks	Multiple variants of DNN primitives as required for framework integrations
Quarterly update releases	Rapid development ahead of Intel MKL releases

¹ GEMM building blocks are binary.

slide credit: Intel corp.

OPTIMIZED DEEP LEARNING FRAMEWORKS

Deep Learning frameworks that have been optimized for Intel Architectures. All are available on Colfax Cluster.

- ▶ Intel Caffe – [GitHub](#)

```
u100@c005% /opt/caffe-master
```

- ▶ Intel Theano/Keras – Github [Theano/Keras/](#)

```
import theano; import keras
```

- ▶ Intel Torch – [GitHub](#)

```
u100@c005% /opt/torch
```

- ▶ TensorFlow – [GitHub](#) (up-streamed)

```
import tensorflow
```

- ▶ Intel MXNet – [GitHub](#)

```
import mxnet
```



EXAMPLE: MNIST WITH TENSORFLOW

MNIST AND TENSORFLOW™

MNIST database

- ▶ Handwritten digit images (28p×28p)
- ▶ Public database
- ▶ 60000 train set, 10000 test set
- ▶ LeCun et. al.



sample digits



TensorFlow™*

- ▶ ML framework developed by Google Inc.
- ▶ Uses data flow graphs
- ▶ Open source library
- ▶ Supports MKL DNN back-end**

* TensorFlow, the TensorFlow logo and any related marks are trademarks of Google Inc.

** Not all versions supports MKL DNN.

OUT-OF-BOX MNIST TENSORFLOW CONVOLUTIONAL NEURAL NETWORK EXAMPLE

Convolutional Neural Network from TensorFlow tutorial, [Deep MNIST for Experts](#)

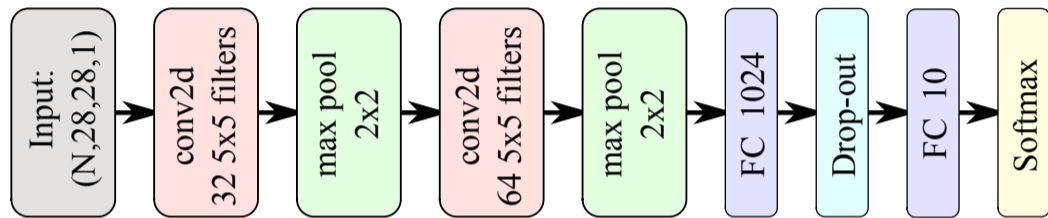

Code and parameters are from the tutorial, but a few changes:

- ▶ Number of batches: 20000 \rightarrow 1000
- ▶ Mini-batch size: 50 \rightarrow 256
- ▶ Using `time.time()` to get the execution time

RUNNING EXAMPLE TENSORFLOW ON COLFAX CLUSTER

Use Intel Python 2.7 Update 3 and GCC 6.3.0 by setting up `~/ .bash_profile`

```
u100@c005% cat ~/.bash_profile
> # ... at the end ...#
> export LD_LIBRARY_PATH=/opt/gcc-6.3.0/lib64/:${LD_LIBRARY_PATH}
> export PATH=/opt/gcc-6.3.0/bin/:${PATH}
> export PATH=/opt/intel/intelpython_update_2/intelpython2/bin/:${PATH}
```

Inside the job script:

```
numactl -m 1 python mnist_deep.py --data_dir=/opt/data/MNIST
```

Out-of-box result (Intel Xeon Phi processor 7210):

```
step 100, accuracy= 0.875
// .... //
step 900, accuracy= 0.957031
Completed in 2498.61 seconds
Test accuracy = 0.9764
```

NHWC VS NCHW

By default TensorFlow uses **NHCW** (batch, height, width, channel) tensors.

MKL DNN prefers NCHW (batch, channel, height, width)

- ▶ Use NCHW for `tf.reshape()`

```
# NCHW (batch, channel, height, width)
tf.reshape(x, [-1,1,28,28])
```

- ▶ Specify `data_format='NCHW'` and change strides for conv and pool layers

```
# Using NCHW strides
tf.nn.conv2d( ... , strides=[1,1,1,1], data_format='NCHW')
tf.nn.max_pool( ... , strides=[1,1,2,2], data_format='NCHW')
```

- ▶ The `+` operator only does NHWC, so instead use the `tf.nn.bias_add`

```
tf.nn.relu(tf.nn.bias_add(conv(h_pool1, w_conv2), b_conv2, data_format='NCHW'))
```

- ▶ No need to change weights or bias, or fully connected layers

ENVIRONMENT TUNING

Tuning parameters for OpenMP can improve performance.

- ▶ Method 1: inside the job script

```
export KMP_BLOCKTIME=1
export OMP_NUM_THREADS=32
export KMP_AFFINITY=granularity=fine,compact,1,0
```

- ▶ Method 2: inside the python script

```
os.environ["KMP_BLOCKTIME"] = "1"
os.environ["OMP_NUM_THREADS"] = "32"
os.environ["KMP_AFFINITY"] = "granularity=fine,compact,1,0"
```

- ▶ **KMP_BLOCKTIME** – time in ms that threads stay active after parallel regions
- ▶ **OMP_NUM_THREADS** – number of threads that OpenMP uses
- ▶ **KMP_AFFINITY** – controlling mapping from software threads to physical cores

TUNED PERFORMANCE

The same training runs approximately **37x** faster on Xeon Phi processor 7210.

```
# NCHW tensor data format
# KMP_BLOCKTIME=1
# KMP_AFFINITY=granularity=fine,compact,1,0
# OMP_NUM_THREADS=32
# using MCDRAM with "numactl -m 1"
step 100, accuracy= 0.878906
// ... //
step 900, accuracy= 0.972656
Completed in 67.7578 seconds
Test accuracy = 0.9757
```

Conclusion

Use proper data format and tune environment variables when using ML libraries

For more, see the [Intel article](#)



§8. CLOSING WORDS

CODE MODERNIZATION

Code Modernization

Optimizing software to better utilize features available in modern computer architectures.

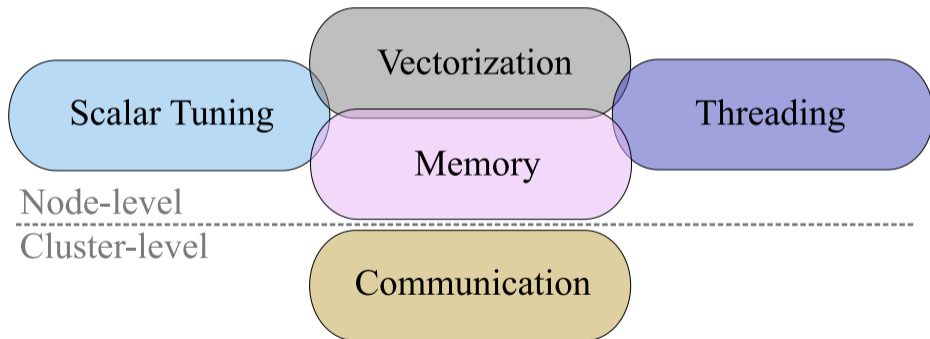



THE "HOW" SERIES TRAINING

DEEP DIVE

WITH CODE MODERNIZATION EXPERTS

It's free

→ [HOWSERIES.COM](https://howseries.com)

*10x 2-hour sessions | 24-hour 2-weeks remote access to a system